



OPERATOR MANUAL

# TDA150

[www.STARTinternational.com](http://www.STARTinternational.com)

4270 Airborn Dr., Addison TX, 75001, +1 972.248.1999

# Table of Contents

---

|  |           |
|--|-----------|
| <b>General Description</b>                           | <b>03</b> |
| <b>Specifications</b>                                | <b>03</b> |
| <b>Safety Precautions</b>                            | <b>03</b> |
| <b>Features</b>                                      | <b>04</b> |
| <b>Description of Parts<br/>and Functions</b>        | <b>05</b> |
| <b>Operation</b>                                     | <b>06</b> |
| <b>How to Operate</b>                                | <b>07</b> |
| <b>Basic Troubleshooting</b>                         | <b>09</b> |
| <b>Maintenance</b>                                   | <b>09</b> |
| <b>Technical, Customer<br/>Service &amp; Returns</b> | <b>10</b> |
| <b>Warranty</b>                                      | <b>10</b> |
| <b>Repair Policy</b>                                 | <b>10</b> |
| <b>TDA150<br/>Exploded Views</b>                     | <b>11</b> |
| <b>TDA150 Parts List:</b>                            | <b>18</b> |
| <b>Declarations of Conformity</b>                    | <b>20</b> |

# General Description

This equipment is designed for dispensing a wide variety of pressure sensitive tapes, therefore it has been positioned on a table top allowing a vertical-down tape dispensing in front of the table edge. The device features a multitude of settings in cut length and dispensing modes. Applicable to the TDA150-Electric Tape Dispenser including models: TDA150-2, TDA150-M, TDA150-M-2, TDA150-NS-LF, TDA150-NS-LF-2, TDA150-NM, TDA150-NM-2, TDA150-NM-NS-LF, TDA150-NM-NS-LF-2.

# Specifications

|                       |   |
|-----------------------|---|
| Model Name:           | TDA150 (-2 for 220V version)                              |
| Tape Width:           | .25" to 5.9" (6 to 150mm)                                 |
| Cut Length:           | 1.6" to 394" (40 to 9999mm)                               |
| Max Outside Dia Roll: | 9" (228mm)  |
| Core Diameter:        | 3" (76mm)   |
| Accuracy of Cut*:     | +/- .04" (1mm)  |
| Feed Speed:           | 6.6"/sec (16.8cm/sec)                                     |
| Weight:               | 38lbs. (17kgs)  |
| Dimensions:           | 10"(L) x 13"(W) x 13"(H) (25cm (L) x 33cm (W) x 33cm (H)) |
| Power Supply:         | 115 VAC 60 Hz or 230 VAC 50 Hz < 2 A                      |

Before using the equipment, read and familiarize yourself with the following operating and safety instructions (SAVE THESE INSTRUCTIONS FOR FUTURE REFERENCE). Save the original box and packaging to ship the equipment if repairs are needed.

# Safety Precautions

To ensure safe operation, read the following statements and understand their meaning. This manual contains safety precautions which are explained below. Please read carefully.



## WARNING

Warning is used to indicate the presence of a hazard that will or can cause severe personal injury or death.



## CAUTION

Caution is used to indicate the presence of a hazard that will or can cause minor or major personal injury if the caution is ignored.

**NOTICE:** Notice is used to note information that is important but not hazard-related.



## WARNING

Severe injury can occur if this equipment is not used properly

To reduce risk of injury or damage to the machine:

- Keep out of reach of children.
- Do not turn equipment on unless all guards are in place.
- Do not feed material by hand: always allow the machine to forward the material.
- Machine must be connected to a properly grounded electrical supply matching the nameplate rating.
- Always unplug machine before cleaning.
- Do not place hands or any object in the cutting zone when blade is active.
- Keep machine away from water; avoid water jets during cleaning.
- Machine should only be used in a flat, leveled position.
- Do not operate unattended.
- Install or locate this machine only in accordance with the provided installation instructions.
- Do not operate this machine if it has a damaged cord or a plug, if it is not working properly or if it has been damaged or dropped.
- Do not immerse the cord or plug in water. Keep the cord away from heated surfaces.
- Do not use an extension cord with this machine. Do not plug this machine into a power strip or multi-outlet power cord.
- Do not spray controls or outside of machine with liquids or cleaning agents.
- Keep machine and power cord away from open flames, electric burners or excessive heat.
- Do not leave tape dispenser in direct sunlight.
- Do not use in dusty or very humid locations.

## Features

Your START International heavy-duty TDA150, automatically dispenses by measuring and cutting adhesive pressure sensitive tapes.

- Ideal for heavy-duty industrial production.
- All-metal gears and advancement rollers
- 4 modes of operation: manual feed-manual cut, manual feed and cut, auto feed and cut and interval feed and cut
- Guillotined cut for a straight edge piece of tape
- Digital push switch display for easy length adjustments
- Safety interlock
- Accuracy +/- .04" (1mm) (dependent on type of tape)
- 9" (229mm) maximum outside diameter roll
- Comes with 3" (76mm) diameter core
- Optional foot switch available, see Accessories section
- Anti-static brush option

# Description of Parts and Functions

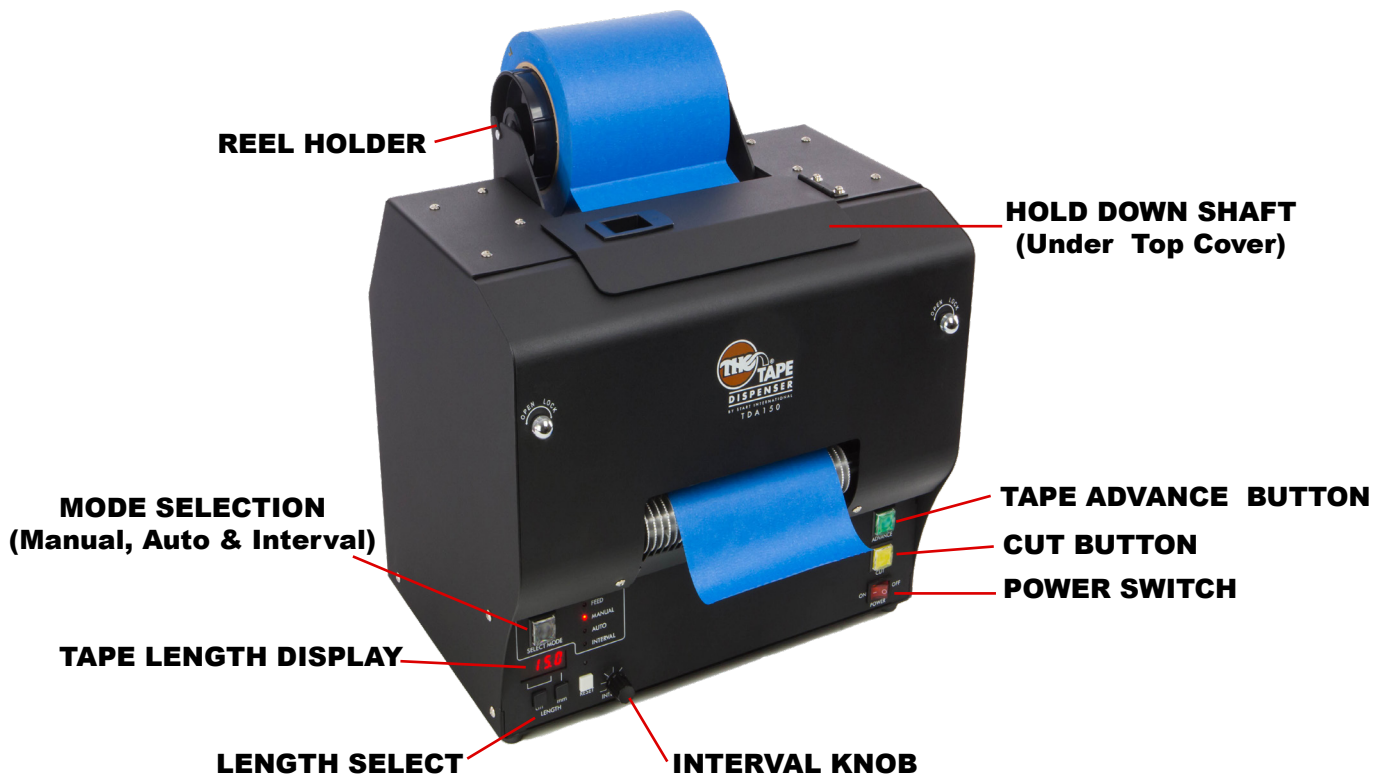

1. REEL HOLDER - 3" core to hold material.
2. HOLD DOWN SHAFT - Increases adhesion to feed roller.
3. TAPE ADVANCE BUTTON - Press to feed and cut one piece of tape to the preset length.
4. CUT BUTTON - Initiates the cut of the material.
5. POWER SWITCH - Press to turn power On and Off.
6. INTERVAL KNOB - Sets delay time before dispensing next piece.
7. LENGTH SELECT - Sets cut length from 1.6" to 394" (40-9999mm).
8. TAPE LENGTH DISPLAY - Shows preset cut length.
9. MODE SELECTION - Toggles operating mode between Feed, Manual (press Tape Advance button to dispense), Auto (automatic feed and cut when piece is removed), and Interval.

# Operation



**WARNING**

Severe injury can occur if this equipment is not used properly



**WARNING**

Cut and Amputation Hazard

The blade on this machine is extremely sharp. Severe injury can occur if care is not used when cleaning or replacing the blade. Only trained personnel should operate equipment or perform maintenance. To reduce the risk of injury, the use of cut resistant gloves is recommended.



**WARNING**

Electrical Shock Hazard

Keep water and other liquids from entering the inside of the equipment. Liquid inside the equipment could cause an electrical shock. Do not spray water or cleaning products. Liquid could contact the electrical components and cause a short circuit or an electrical shock.

10

# How to Operate

## How to load the material into the TDA150:

### 1. Power Off.

A: Ensure power button is set to off.

### 2. Load Tape.

A: Slide tape roll onto core holder.

B: Place loaded core on holding a bracket.

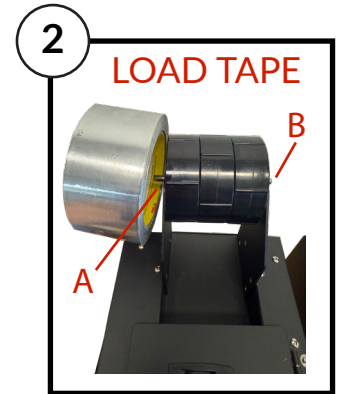
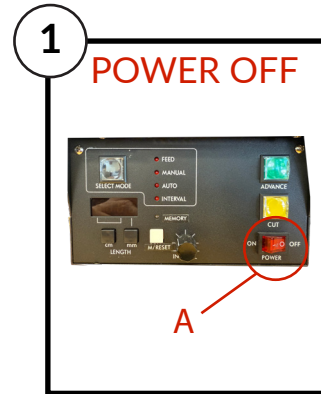

### 3. Open Top Panel.

A: Open top door panel.

B: Remove hold down shaft guide from unit.

### 4. Affix Tape to Feed Roller

A: Affix tape onto tape roller.

B: Reinsert hold down shaft into guide.

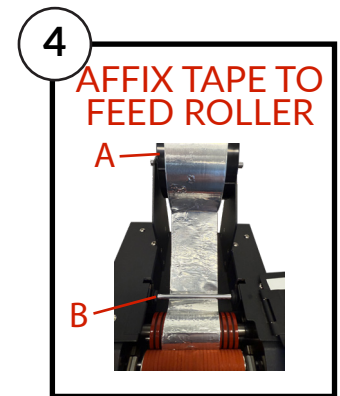
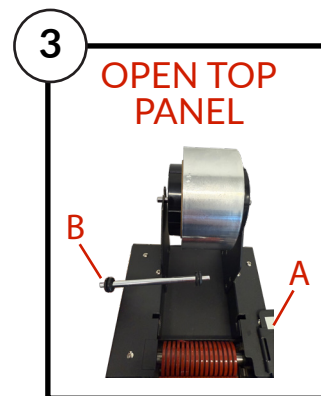

### 5. Plug In-Turn On

A: Connect power cord (in back).

B: Press power switch (on front) to turn on the machine.

### 6. Feed Tape.

A: Close top panel door.

Set Mode to FEED

B: Press advance button to feed tape.

C: CUT TAPE

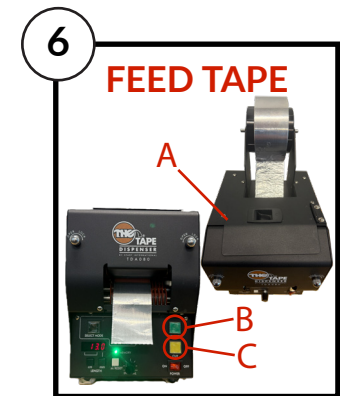
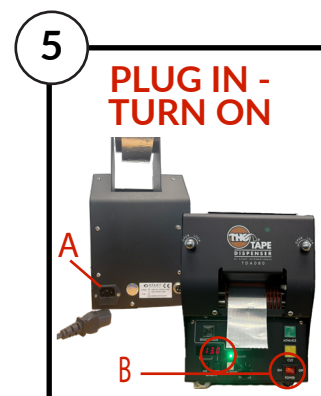

### 7. Select Mode.

A: Choose desired operation mode:

MANUAL (feed & cut)

AUTO (feed & cut)

INTERVAL (feed & cut) - Adjust with interval knob

### 8. Selecting Length.

A: Set desired tape length (mm) by pushing cm and mm buttons.

(reset by pressing RESET button)

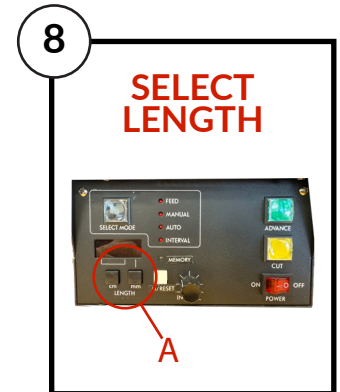
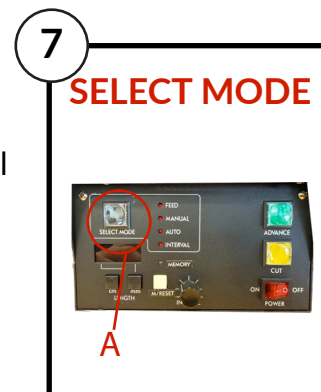

### 9. Start dispensing.

## Setting programmable memories for the TDA150-M:

There are 5 programmable memories and 2 additional modes with the TDA150-M

### *The PRES mode...*

You can select memory 1 through 5 and the unit will cut and dispense at the length programmed into the selected memory. Simply select the memory location you want by pressing and then releasing the M/Reset button.

### *The LOOP mode...*

You can select memory 1 through 5, the unit will start dispensing at the selected memory length and then with each cut the unit will automatically sequence to the next programmed length. After reaching the last programmed length the unit will loop back to memory 1 and start sequencing again. See Advanced LOOP Mode Functions for more details.

Both of these additional modes will work in conjunction with the manual, auto or interval modes.

## TDA150-M Memory Programming Procedure

### *To enter the memory and mode programming procedure.*

- Press and hold the white M/Reset button until the display blinks rapidly.

### *To set a memory length or select the PRES/LOOP modes.*

- While the display is blinking, press and hold the white M/Reset button to see the number of the memory location or the PRES/LOOP modes.
- Each press and hold of the M/Reset button selects the next memory location.
- Release the M/Reset button to see the length set in the previously displayed memory location or to change the length set in the previously displayed memory location.

### *Blinking display sequence:*

1-→Length-→2-→Length-→3-→Length-→4-→Length-→5-→Length-→PRES or LOOP-→back to 1

### *To select between PRES or LOOP modes.*

- While the display is blinking, press and release the M/Reset button until the display blinks PRES or LOOP (see above).
- Press the mm button to select either PRES or LOOP.

### *To exit and save the memory and mode programming procedure.*

- Press and hold the white M/Reset button while the display is blinking until the display stops blinking.

To review the length settings in the 5 memory locations.

### *While the display is not blinking.*

- Press and hold the white M/Reset button to see the first memory location.
- Release the M/Reset button to see the length set in the first memory location.
- Continue to press the M/Reset button to review each memory location and release the button to review the length set for that location.

### *Non-blinking display sequence:*

1-→Length-→2-→Length-→3-→Length-→4-→Length-→5-→Length-→back to 1

### *Advanced LOOP mode Functions*

- It is not required to LOOP through all 5 memories. If desired you may LOOP through less than 5 memories by setting the unwanted memories to 999.9cm using a HARD RESET.
- A HARD RESET will set memory location 1 to 4cm and the other memories to 999.9 cm. To perform a HARD RESET start with machine powered off, press and hold the M/Reset button while turning the machine on.
- After performing a HARD RESET you may set the length in the desired number of memories by using the set memory length procedure described above.

**NOTE:** To RESET the length in the display to 4 CM at any time during the run or memory set procedures press and hold the mm button and then press the cm button.

# Basic Troubleshooting

When problems occur, carry out the following procedures.

If the tape dispenser does not operate normally after following the troubleshooting procedures, contact your supplier or START International.

*No power light/Tape does not feed:*

- Unplug unit and plug in again.
- Turn power switch off, wait 5 seconds, turn unit back on.
- Check that front panel is closed securely, and safety interlock is engaged.
- Verify that the fuse has not blown.
- Check that Tape Length Display is 40 mm or greater.

*Tape does not feed when unit is in AUTO mode:*

- Check that Auto/Manual Switch is in correct position.
- Turn Interval Knob all the way counterclockwise.
- Wait 1 full second after tape is cut before removing tape from machine.

*Blade sticks in closed position:*

- Apply silicon oil (P/N - zcM1000P289) to #242 Blade Roller.

*Tape is not cut completely through:*

- Replace #279S with #279FS fully serrated blade

# Maintenance

## 1. Cleaning:



**WARNING**

- Weekly - Wipe feed rollers and blade with a cloth and isopropyl alcohol to remove adhesive build-up.
- Monthly - Apply silicone oil (P/N - zcM1000P289, available from START International) to blade rollers. Inspect pressure rollers and cutting blade for wear.
- For video instruction visit: <https://vimeo.com/1033266361>

## 2. Replacing Blades:



**WARNING**

- Step 1: Lift top cover, open front panel
- Step 2: Unscrew blade screw, remove blade
- Step 3: Replace blade, secure with screw
- Step 4: Close panel and top cover

Step 1

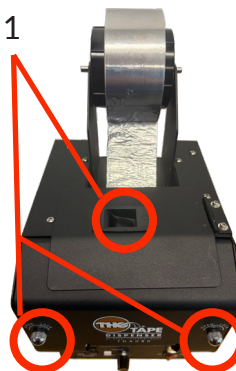

Step 2

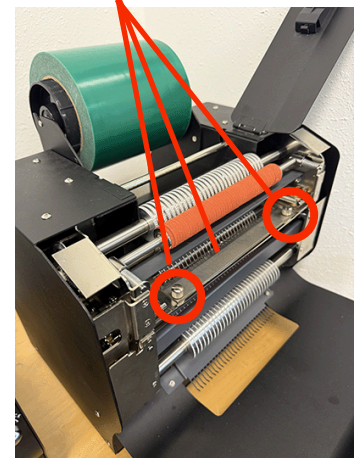

## 3. Replacing Pressure Roller Rings:

- For video instruction visit: <https://vimeo.com/1032090892>

# Technical, Customer Service & Returns

For technical support or customer support, please visit [www.startinternational.com](http://www.startinternational.com) for details, instructional videos, or guides. Please call START International Customer Support at +1 (972) 248-1999, Monday-Friday; 9AM-5PM CST. In Europe at +34 615 036-429, Monday-Friday, 9AM-5PM CET

If a malfunction is detected take these steps to resolve any technical issue:

1. Please contact your customer service representative to describe the nature of your problem and to determine if your product is covered under warranty. Do not attempt to disassemble or repair the machine prior to talking to a representative or the warranty will be void.
2. Provide the product number, serial number and brief description of the issue.
3. Submit pictures and short videos of the issue (over 90% of most problems are resolved with a video-call).
4. However, if it is determined that your product needs to be submitted for repair an RMA (Return Metric Authorization) number will be assigned. Shipping a product to us without an RMA # may delay your service.
5. Please make sure to package your product properly with an excess amount of packaging material in order not to expose your product to shipping damage. Shipping damage is not covered under warranty.
6. Upon receiving the machine our START technician after 5 business days will send you feedback or schedule a videoconference. Once the repair is made and the machine has been sent back, after 2 weeks the work ticket will close, if no issues are reported.

## Warranty

START International warrants all parts on the TDA150 tape dispenser against defects in design, materials and workmanship. Please refer to our warranty policy.

The warranty does not cover the cutting blade, springs, pressure rollers, or other expendable parts, as these are expected to wear out with regular use and are not considered defective.

## Repair Policy

Contact START International to determine nature of problem.

**For customers in North America and South America email: [info@startinternational.com](mailto:info@startinternational.com)**

**For customers in Europe and Africa email: [europe@startinternational.com](mailto:europe@startinternational.com)**

Provide START International the following information:

1. Who the unit was purchased from.
2. Model number and serial number.
3. Date purchased (copy of invoice or packing slip required).

START International will issue an RMA (Return Metric Authorization) for the repair.

Return machine to START International, insured and prepaid.

START International will notify the customer if there is a repair charge.

A \$25.00 evaluation charge will apply to all non-warranty repairs, and will be applied to subsequent repair charge.

# TDA150 Exploded Views:

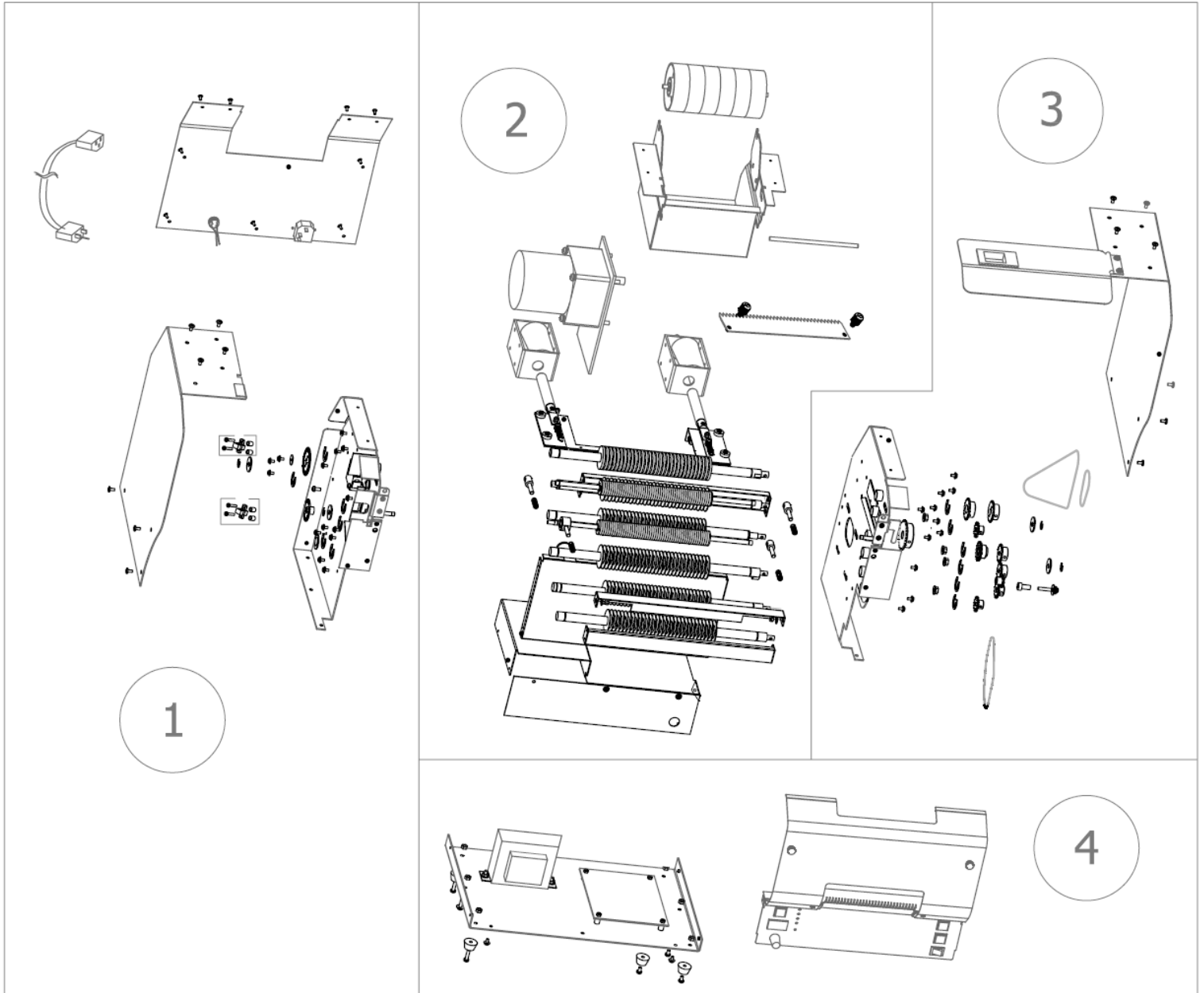

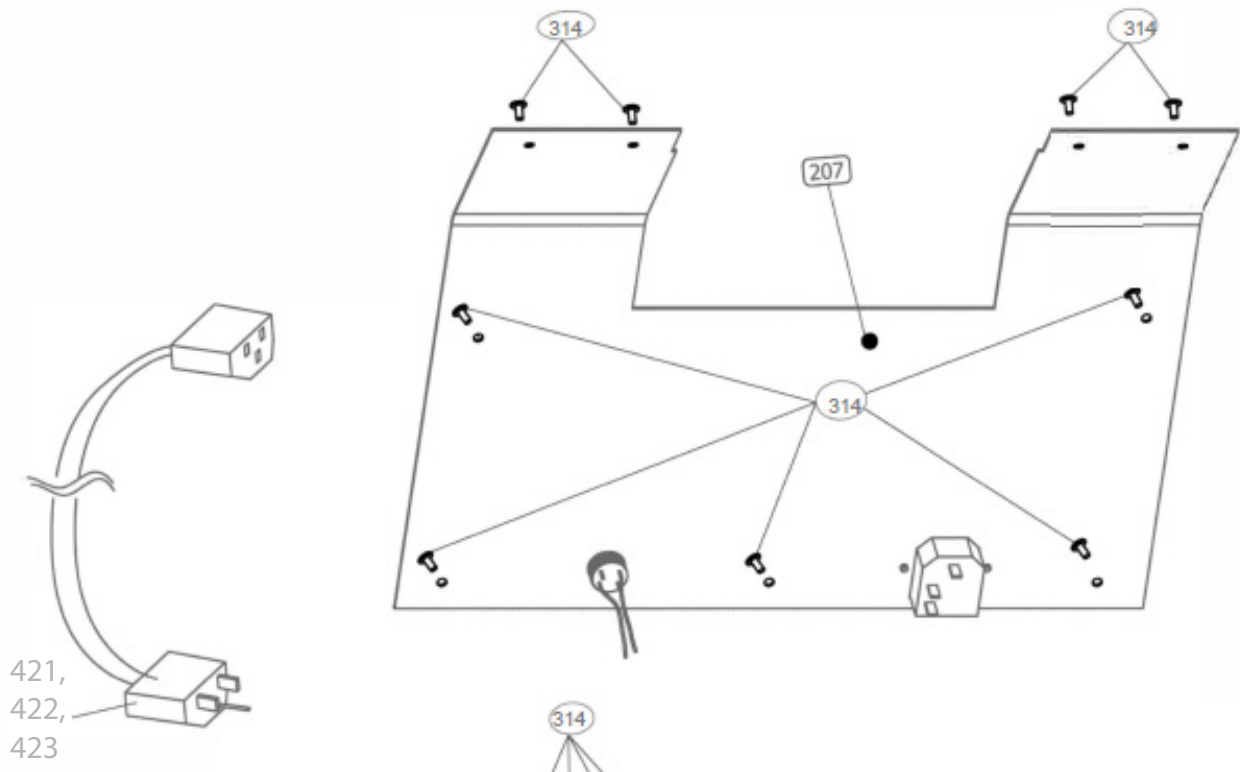

1

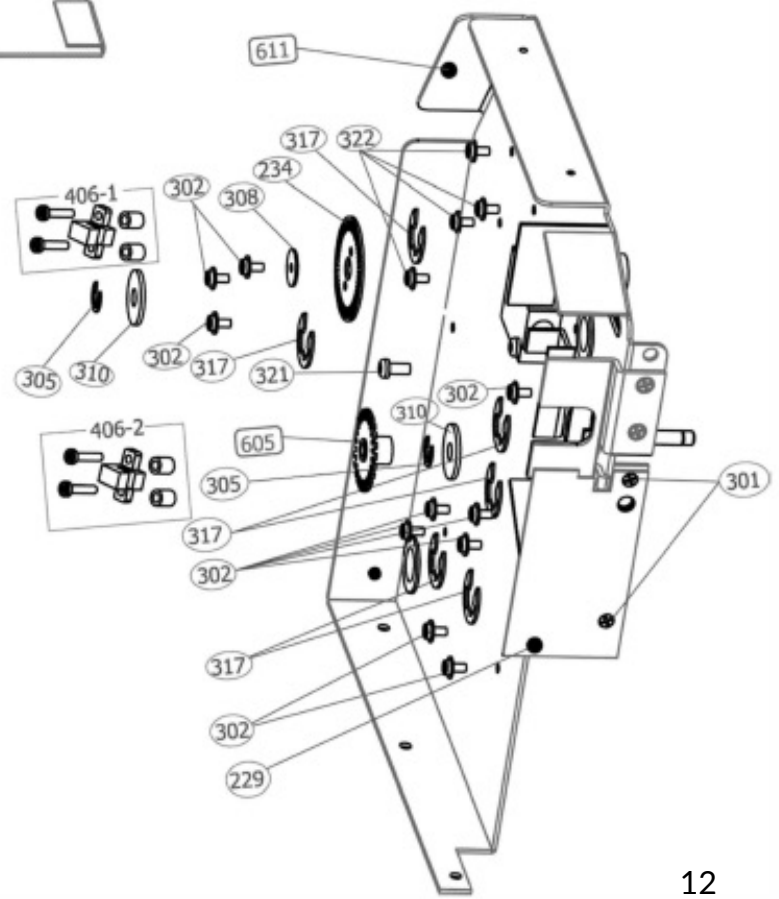
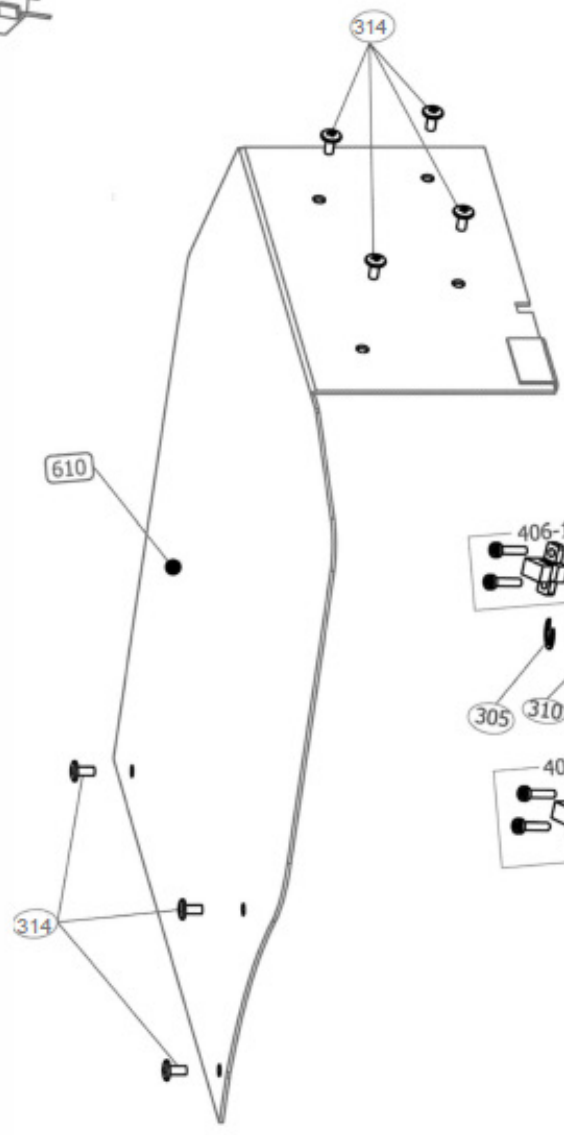

2

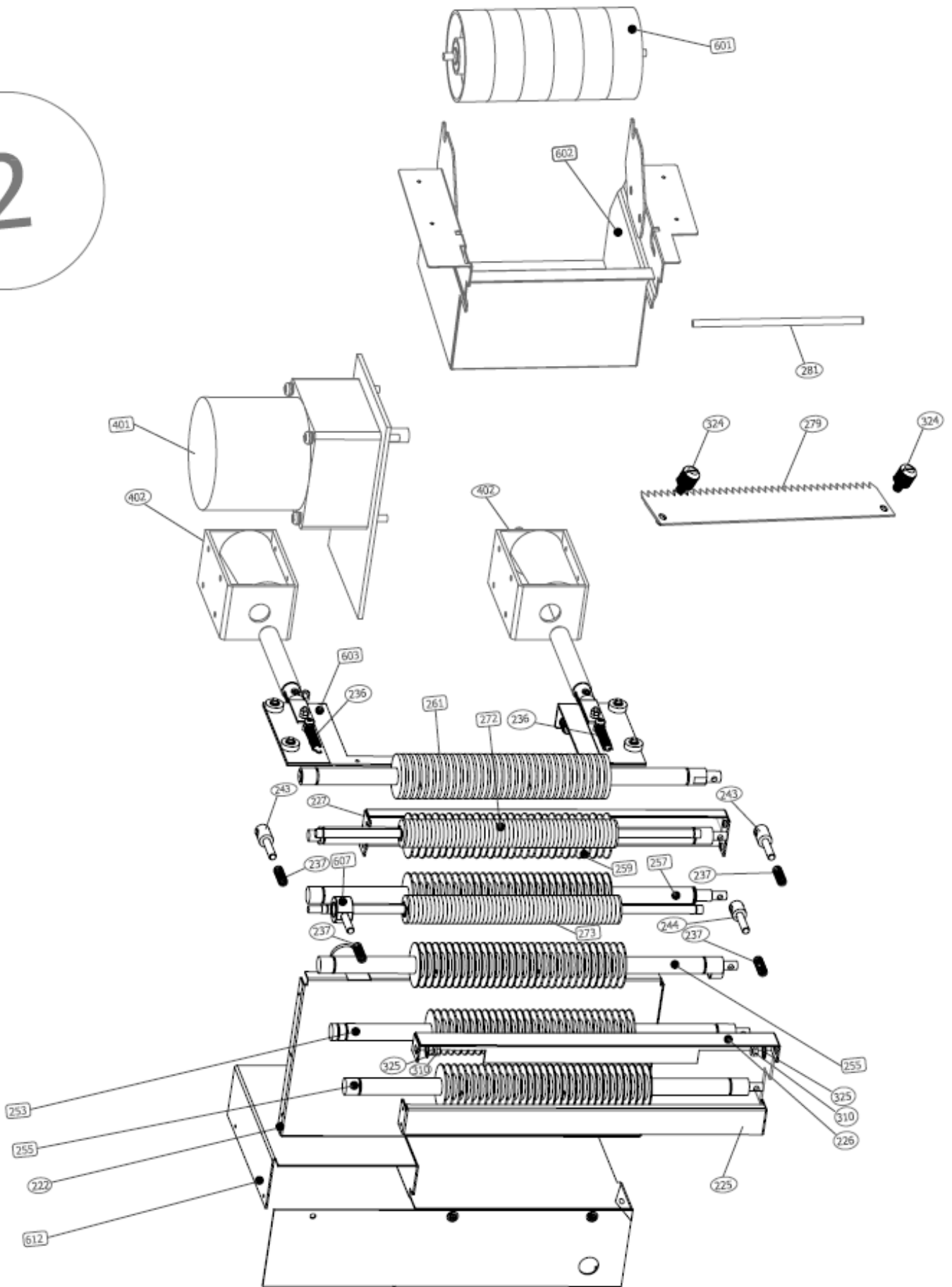

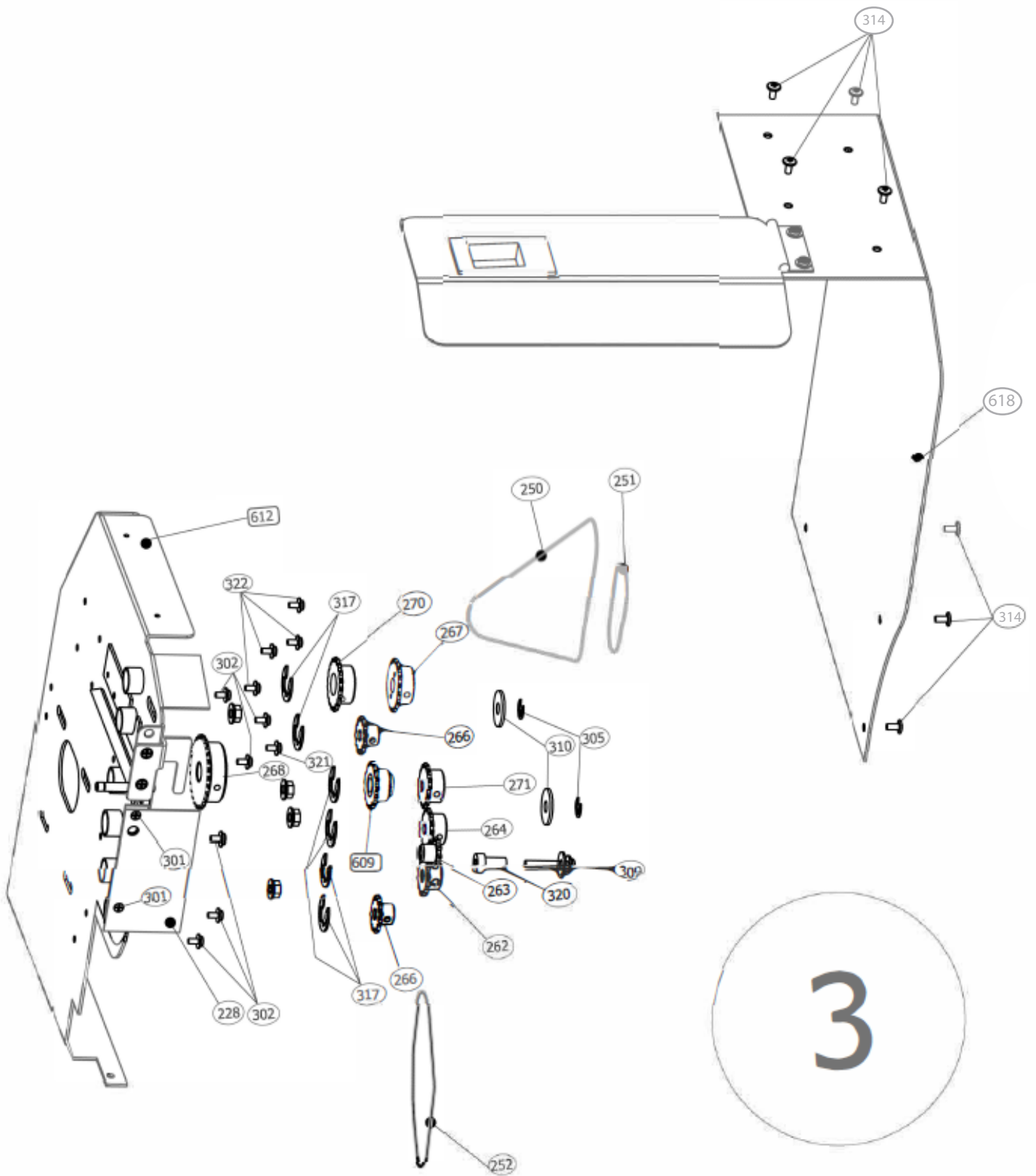

# 4

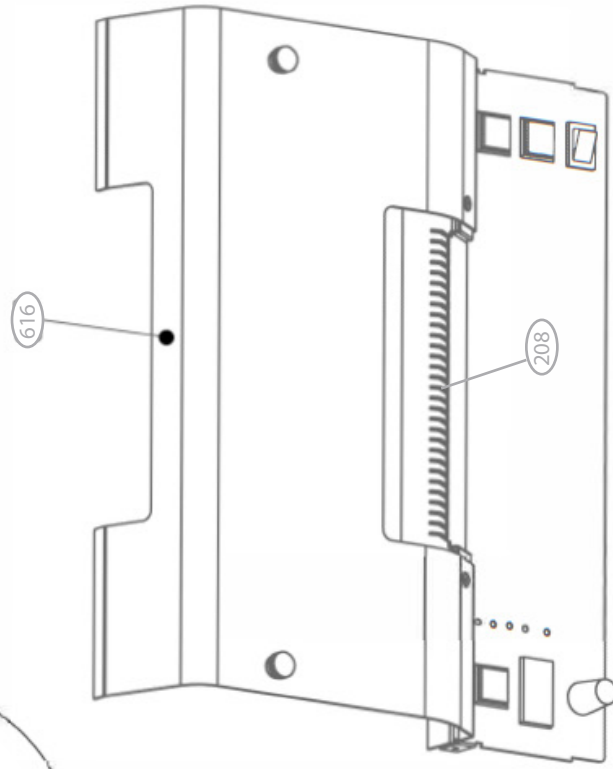
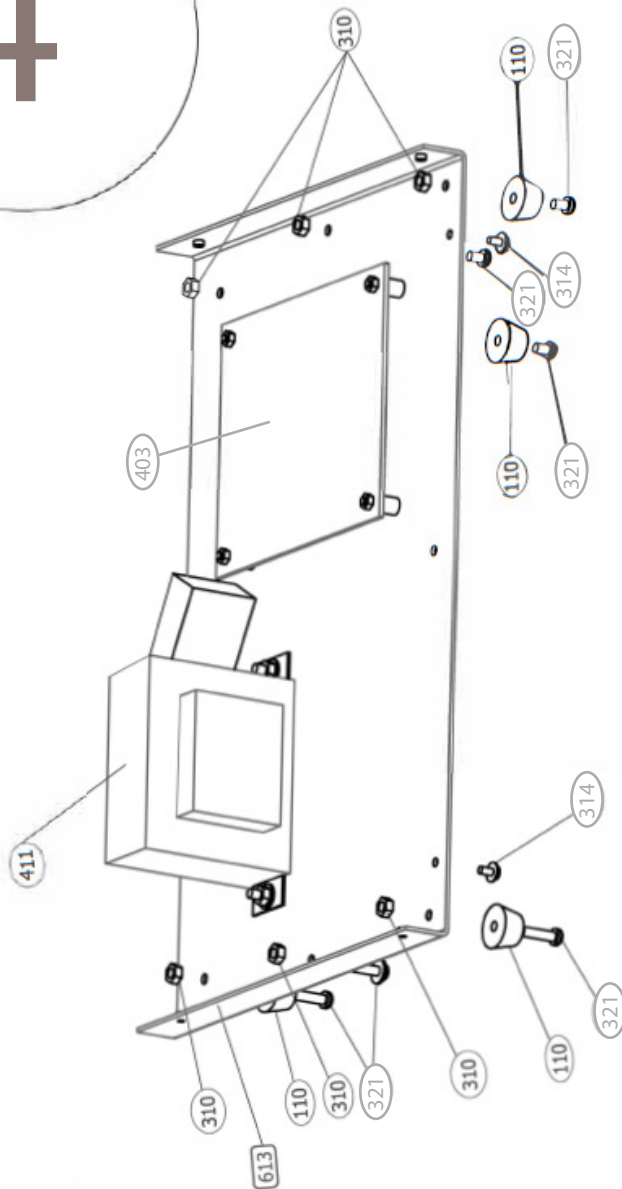

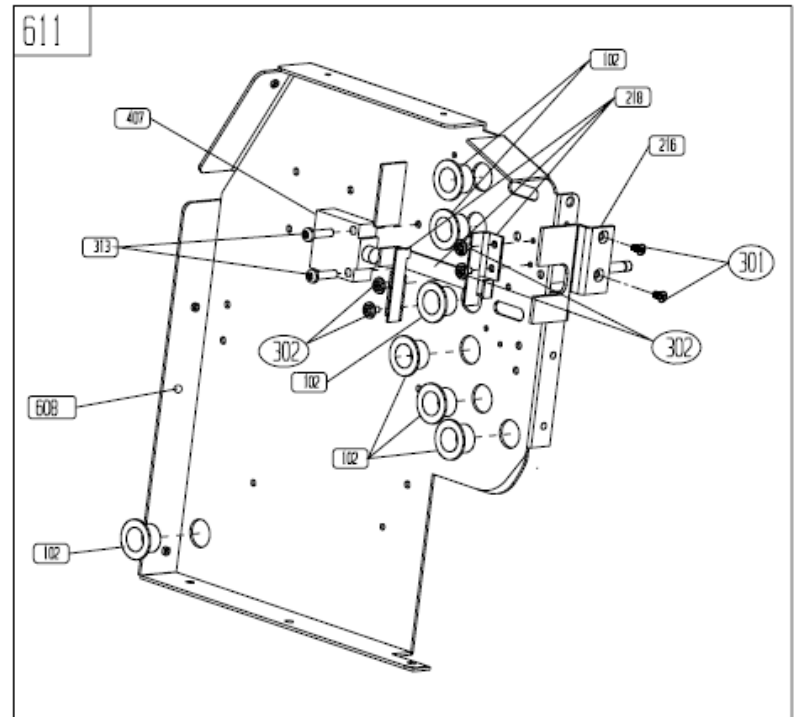
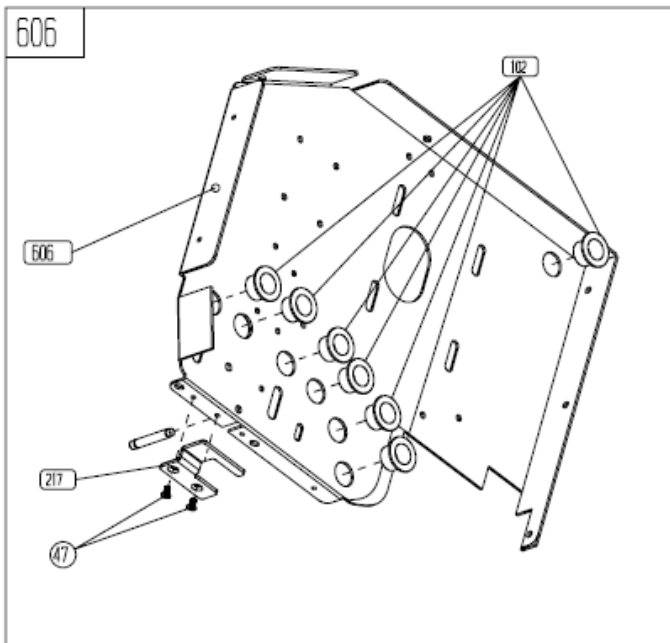
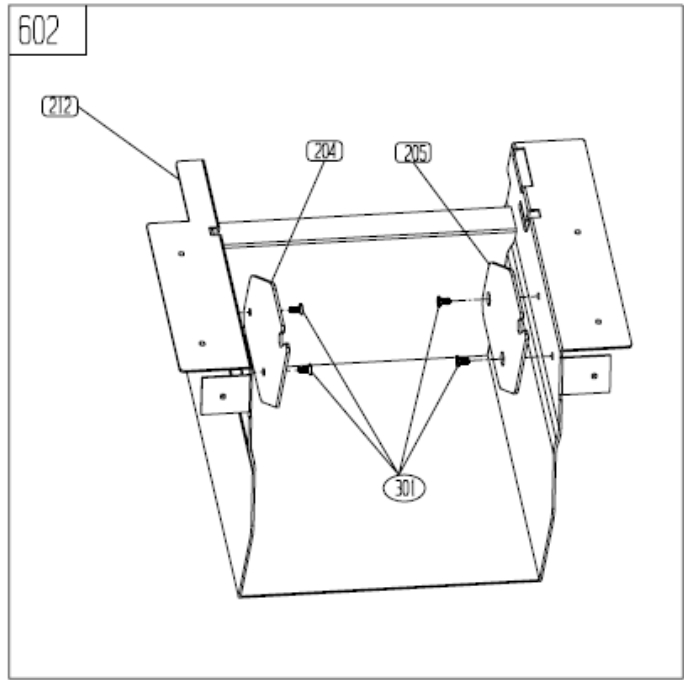
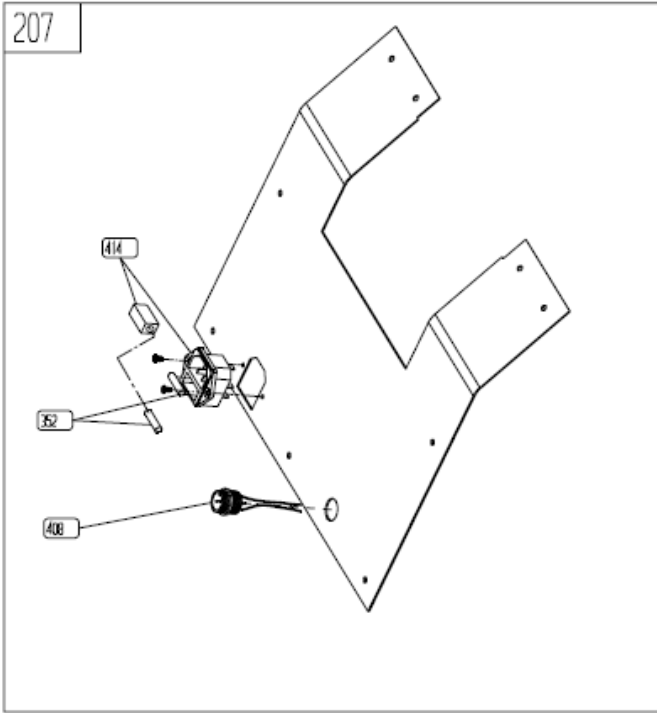

612

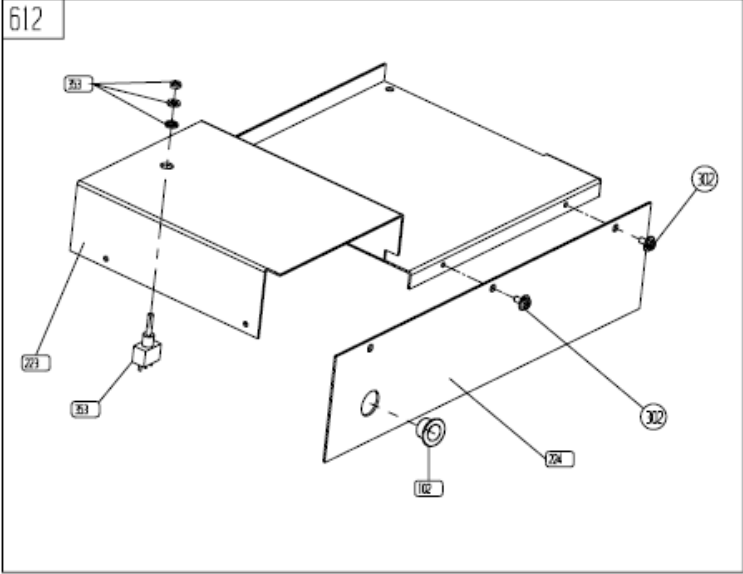

613

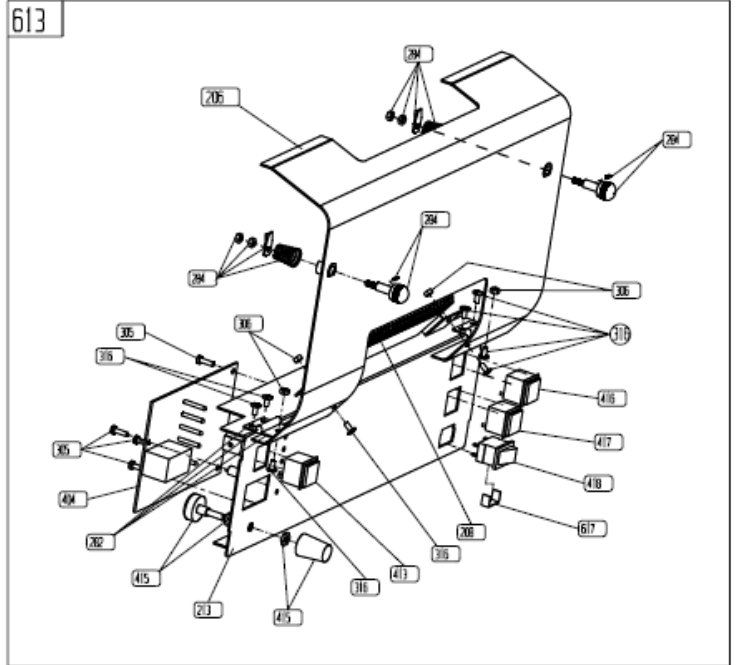

614

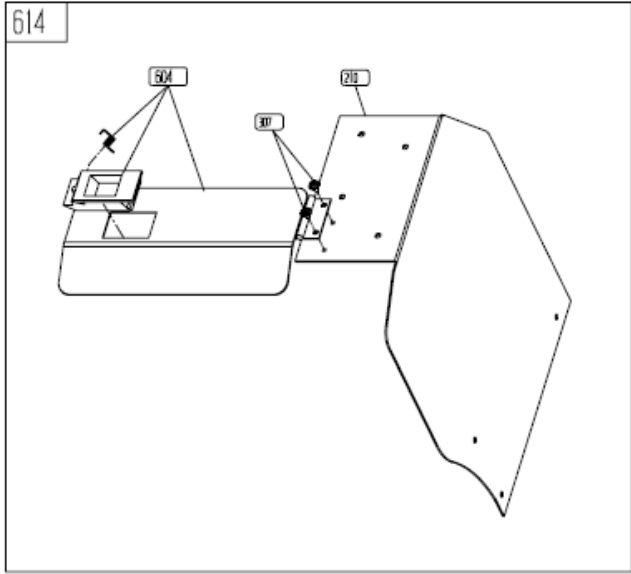

615

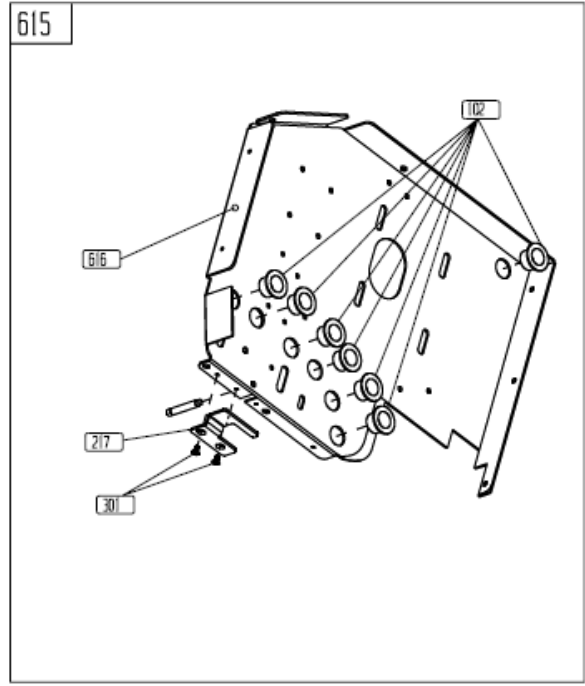

# TDA150 PARTS LIST:

| Part #         | Section # | Description                             |
|----------------|-----------|---|
| TDA080P102     | 1,3       | Plastic sleeve                          |
| TDA080P110     | 4         | Rubber feet                             |
| TDA150P207     | 1         | Rear Panel Assembly                     |
| TDA150P208     | 4         | Tape guide for TDA150                   |
| TDA150P223     | 2         | Bottom Inner Plate                      |
| TDA150P226     | 2         | Front Plate                             |
| TDA150P227     | 2         | Back connection plate                   |
| TDA080P234     | 1         | Feed detection wheel                    |
| TDA080P236     | 2         | Cutter frame spring                     |
| TDA080P238     | 2         | Pressure Roller Spring                  |
| TDA150P243-B   | 2         | Slide Pin (for pressure roller A) (NEW) |
| TDA150P244-B   | 2         | Slide Pin (for pressure roller B) (NEW) |
| TDA150P250     | 3         | Drive Chain                             |
| TDA080P251     | 3         | Feed chain #1 (upper)                   |
| TDA150P252     | 3         | Feed chain #2 (Lower)                   |
| TDA150P253-B   | 2         | Bottom Feed Roller (NEW)                |
| TDA150P255-B   | 2         | 4th Feed roller (NEW)                   |
| TDA150P257-B   | 2         | 3rd Feed Roller (NEW)                   |
| TDA150P259-B   | 2         | 2nd Feed roller (NEW)                   |
| TDA150P261-B   | 2         | Top Feed Roller (NEW)                   |
| TDA150P262     | 3         | Sprocket gear (13T)                     |
| TDA080P263     | 3         | Sprocket wheel (10T)                    |
| TDA080P264     | 3         | Sprocket wheel (14T)                    |
| TDA080P266     | 3         | Sprocket wheel (12T)                    |
| TDA080P267     | 3         | Sprocket wheel (18T)                    |
| TDA080P271     | 2         | Sponge Pressure Ring                    |
| TDA150P272-B   | 2         | Pressure roller A (NEW)                 |
| TDA150P272-B-1 | 2         | Bush A for Pressure Roller              |
| TDA150P273-B   | 2         | Pressure roller B (NEW)                 |
| TDA150P273-B-1 | 2         | Bush B for Pressure Roller              |
| TDA150P279S    | 2         | Cutter Blade for TDA150                 |
| TDA150P281     | 2         | Pressing Tape shaft                     |
| TDA080P284A    | 4         | Knob shaft with HW                      |

# TDA150 PARTS LIST . . . continued:

| Part #       | Section # | Description                            |
|--------------|-----------|--|
| TDA080P302   | 1, 3      | XSN#1/8" +W6                           |
| TDA080P310   | 4         | Nut (for rubber feet) 5/32"            |
| TDA080P314   | 1, 3, 4   | Exterior Screw XSN#1/8"+W6             |
| TDA080P321   | 1, 4      | Screw 5/32 x 8                         |
| TDA080P322   | 2         | Solenoid Screw Bolt M3.0 x 6           |
| TDA150P324   | 2         | Blade Screw (5/32 x 4)                 |
| TDA080P325   | 2         | Washer (Black Berce)                   |
| TDA150P401   | 2         | Motor Unit (with gear box & capacitor) |
| TDA080P402   | 2         | Solenoid Unit                          |
| TDA080P403-C | 4         | Main PCB current ver. 6 connectors     |
| TDA080P404B  | 4         | Control PCB Digital Display No memory  |
| TDA080P404M  | 4         | Control PCB Digital Display Memory     |
| TDA080P406-1 | 1         | Length Encoder                         |
| TDA080P406-2 | 1         | Feed Encoder                           |
| TDA080P413   | 4         | Select mode switch                     |
| TDA080P415   | 4         | Interval switch unit                   |
| TDA080P416   | 4         | Advance button                         |
| TDA080P417   | 4         | Cut button                             |
| TDA080P418B  | 4         | Power switch                           |
| TDA080P419   | 4         | cm-mm button cover                     |
| TDA080P420   | 4         | Reset button cover                     |
| TDA150P601   | 2         | Reel Holder Assy                       |
| TDA150P602   | 2         | Tape holder Assy                       |
| TDA150P603-B | 2         | Cutter Frame Assy (NEW)                |
| TDA080P605   | 1         | Detection wheel Assy with hardware     |
| TDA150P609   |           | Feed Gear                              |
| TDA150P610   | 1         | Cover (Left)                           |
| TDA150P611   | 1         | Left Inner Plate Module (NEW)          |
| TDA150P612   | 3         | Right Inner Plate Module (NEW)/        |
| TDA150P618   | 3         | Cover Assembly (Right)                 |

# DECLARATIONS OF CONFORMITY

Scan the QR code or click on it to download the Declaration of Conformity



Scan the QR code or click on it to access this manual in Spanish, Italian, German, French or Polish.



START International shall not be held liable for any unintentional errors, omissions, or inaccuracies contained within this instruction manual.



4270 Airborn Dr.  
Addison TX, 75001

+1 972.248.1999

[www.STARTinternational.com](http://www.STARTinternational.com)