

OPERATION MANUAL



A portable wrap around labeler
with the efficiency and mobility desired in small production runs

Serial Number:
Electricity:

TABLE OF CONTENTS

MACHINE SPECIFICATIONS

- 04 Machine Sub-Assemblies
- 05 Machine Dimensions
- 07 Specification of Label Reel

GENERAL INFORMATION

- 09 Safety Regulations
- 10 Label Applicator
- 12 Sensitivity Adjusting of Label Sensor
- 13 Position of Object Sensor
- 14 Parts Adjustments
- 15 Control Panel

MACHINE OPERATION

- 17 Machine Operation
- 18 Control Panel Setup
- 20 Control Panel Warnings
- 21 Trouble Shooting

ELECTRONIC PANEL

- 25 Electronic Diagram
- 26 Control Box Frame
- 27 Control Box Parts List

APPLICATOR

- 29 Applicator Exploded View
- 30 Applicator Motor Assembly
- 32 Base Paper Collect Assembly
- 33 Label Peel Plate Assembly
- 34 Applicator Driving Assembly
- 35 Bearing Seat Fixing Plate Assembly
- 36 PU Roller Assembly
- 37 Aluminum Knurled Roller Assembly

38

- 39 Label Supply Assembly
- 40 Label Supply Plate Assembly
- 41 Tension Bar Assembly
- 41 Label Roller Assembly
- 42 Label Sensor Base Assembly
- 43 Label Load Assembly (without printer)
- 44 Label Press Assembly
- 45 Label Press Roller Assembly
- 46 Applicator Adjustment Assembly

WRAP STATION

- 48 Wrap Station Assembly
- 49 Wrap Station Motor Assembly
- 50 Wrap Station Driving Pulley Assembly
- 51 Srap Station Driven Pulley Assembly
- 52 Space Roller Assembly 1

Space Roller Assembly 2

- 53 Wrap Station Up/Down Adjustment Assembly

PRESSURE PLATE

- 56 Pressure Plate Assembly
- 57 Pressure Plate Adjustment Assembly

CONVEYOR

- 59 Conveyor Assembly
- 61 Conveyor Motor Assembly
- 62 Conveyor Driving Pulley Assembly
- 63 Conveyor Driven Pulley Assembly

FOOT STAND

- 65 Foot Stand



MACHINE SPECIFICATIONS

MACHINE SUB-ASSEMBLIES

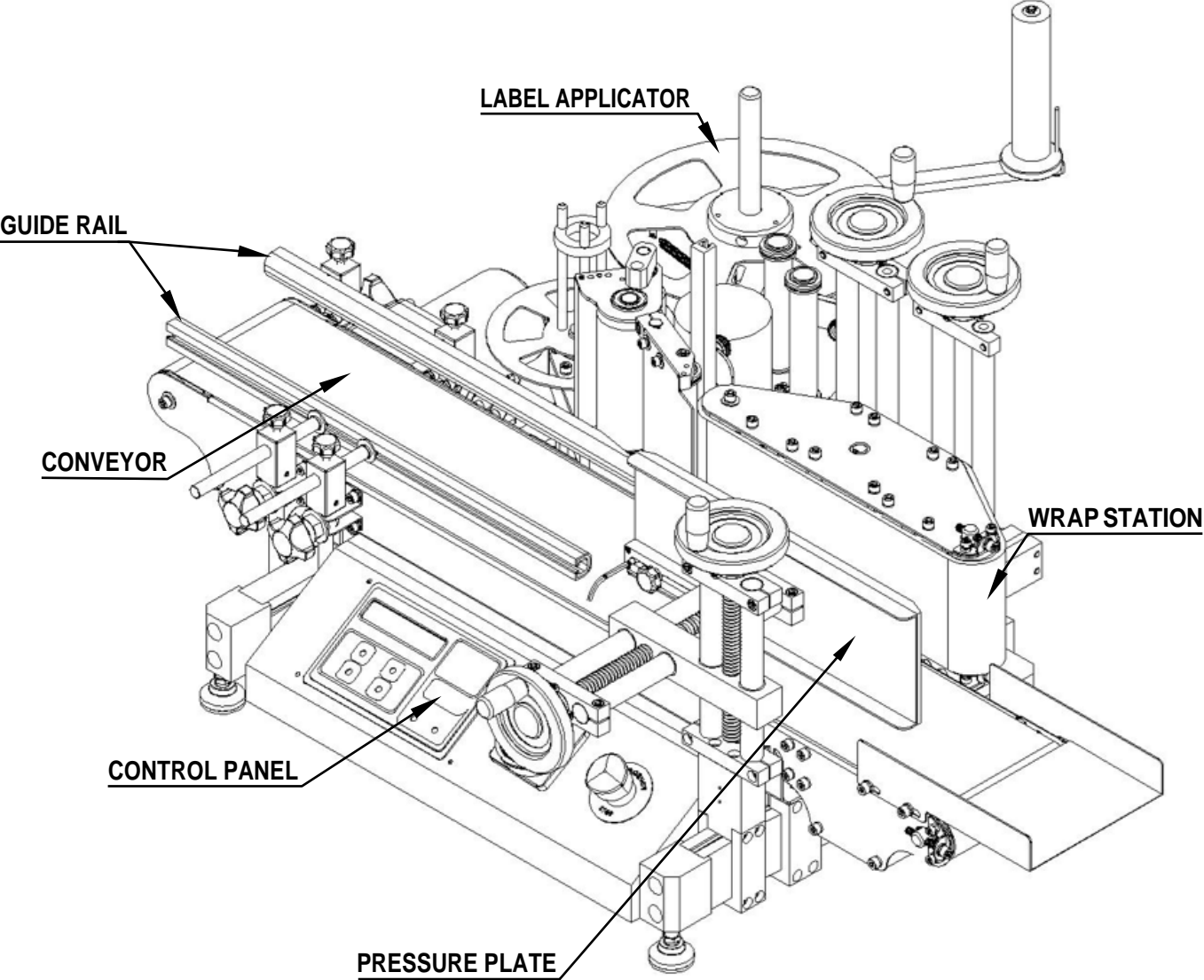

MACHINE DIMENSIONS

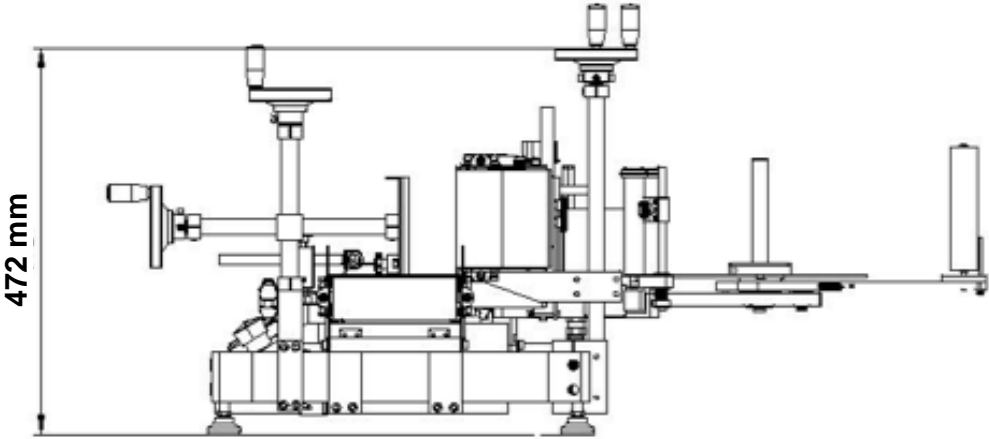
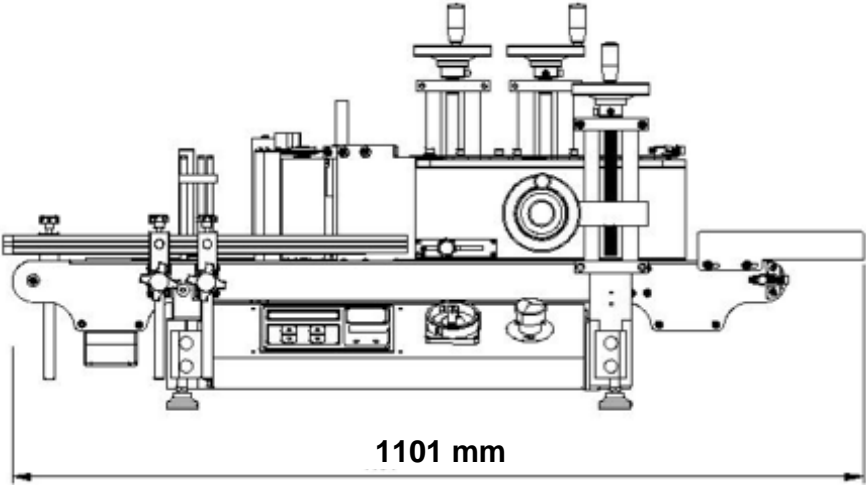
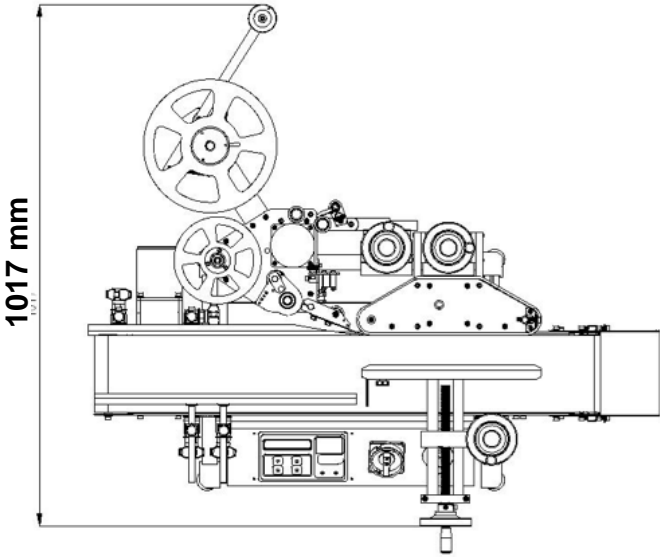

MACHINE DIMENSIONS

LABEL TYPE

Wrap Around

SPEED

Maximum Dispensing Speed:
52.5'/minute, (16m/minute),
60 cont/minute

Maximum Conveyor Speed:
26.2'/minute, (8m/minute),
60 cont/minute

Maximum Conveyor Speed:
4 Levels Selection

DIMENSIONS

Dimensions L-W- H:
43.3" x 34.3" x 20"
(1101mm x 1017mm x 472mm)

Maximum Label Size:
4.75" x 11.8" (120mm x 300mm)

Maximum Container Width:
6.3" (160mm)

Conveyor Width:
6" (160mm)

Spool Diameter: 10" (254mm)
Inner Core: 3" (76mm)

POWER

Voltage: 110/220 VAC 50/60 HZ
1 Phase

Power in KW: .460

Drive: 2 Phase Stepper Motor

NET WEIGHT

Approx 165 lbs (75 kgs)

Flexibility

- The ELF-50's standard one-button teach product and label sensors can be effortlessly adjusted for various labeling applications. And, with the manual position setting, your labels are placed accurately on the product, each and every time.
- It's easy to upgrade the ELF-50 to activate hot-foil printer controls. This integrated feature simplifies label customization and allows the hot-foil printer to work in sync with the labeler to ensure accurate code placement.
- Thanks to the user-friendly operating interface, changing to different labeling applications for various product sizes and types can be done simply and quickly.

Productivity

- A production preset function means the machine automatically stops once the predetermined quantity of products has been labeled.
- The label count feature lets you precisely track progress at any point during the production run.
- The container/production run counter lets you see the exact production number for the day.
- The ELF-50 features a battery-free microprocessor control system that maintains default settings and memory even after the machine sits idle for a long period of time. Up to five settings can be stored for future use, so you don't have to waste time re-entering the necessary information.

Accuracy

- The ELF-50's stepper motor essentially counts the "steps" necessary to reach the next label, ensuring fast, accurate label delivery.
- The ELF-50's controls are fully synchronized, ensuring that all components run at the same speed.

Practicality

- The ELF-50 can be easily and conveniently moved to other production areas, allowing for changes in production or products.
- The ELF-50 is easy to work on and to adjust, putting everything you need at your fingertips with the removal of just a few screws.
- All Pack Leader USA labelers are made of 304 stainless steel and anodized aluminum. This extremely durable metal is specially treated to guard against rusting and other effects from harsher environments.

Compliance

- All Pack Leader USA labelers are manufactured in compliance with Good Manufacturing Practices (GMP) standards and meet the strict ISO 9001 quality control procedures. So, you can have confidence undergoing required quarterly inspections from industry compliance auditors.

SPECIFICATION OF LABEL REEL

Base Paper:

Opaque or Translucent

Reel Inner Diameter:

3" (76 mm)

Reel Outer Diameter:

9.8" (250)mm

Interval of Label:

Min. 3 mm (between label)

Width of Base Paper:

Label Width + 4 mm

Width of Label:

120 H Label Head – 10~120 mm

Length of Label:

15 ~ 300 mm



#4 WIND

**Left side
of copy
dispenses
first.**

NOTE: Label gap must not exceed 5mm or the machine will not function properly.



GENERAL INFORMATION

SAFETY REGULATIONS

INSPECT BEFORE OPERATING

- Make sure the power is connected to the correct power source
- Adjust the object sensor to the correct position
- Adjust label sensor to the proper setting

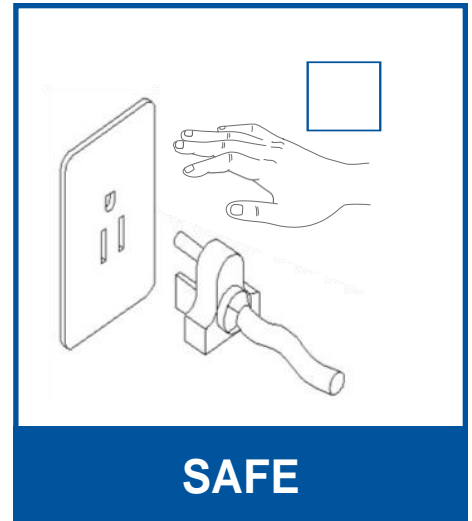

Be sure hands are completely dry before inserting the plug into the outlet. Especially, in the food industries or in wet environments.

LABEL APPLICATOR

Follow these instructions to insert the labels into the label applicator.

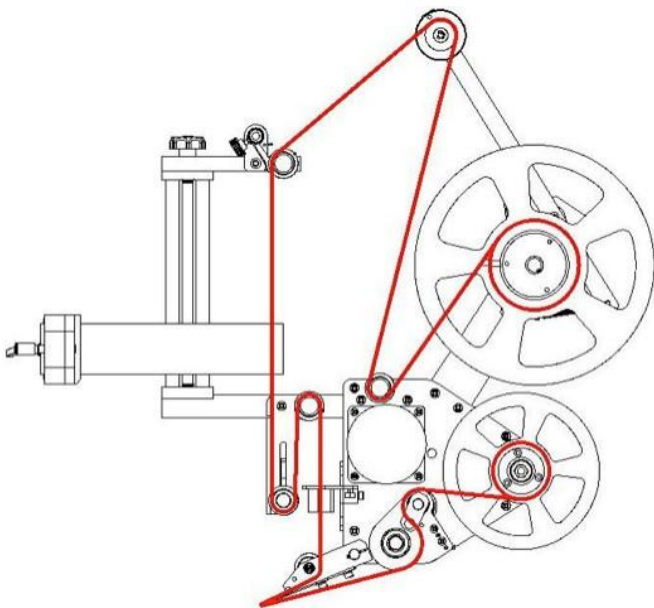

WITH PRINTER

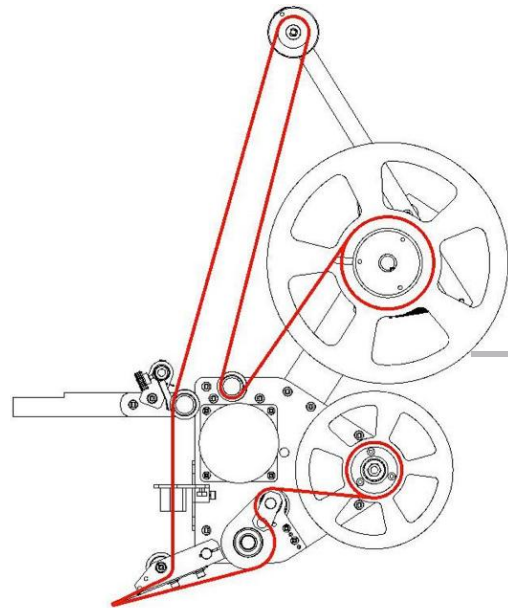

WITHOUT PRINTER

1. Place the label roll on the supply plate and pass the labels around the tension roller to control overrotation of the roll.
2. Secure the labels by adding tension to the label press pad. This will prevent the labels from running loosely.
3. If a printer is installed, pass the labels between the print head and the print pad of the printer.
4. It is important for the labels to pass through the forks of the label sensor and make contact with one side. The label sensor controls the dispensing of the labels.



LABEL APPLICATOR

- 5. The dispensing plates peel the label from the base paper and apply it to the products.
- 6. The PU drive roller pulls the base paper to apply the labels. The aluminum knurled roller must be closed and locked in place with the PU roller in order to squeeze the base paper and pull effectively. See below.

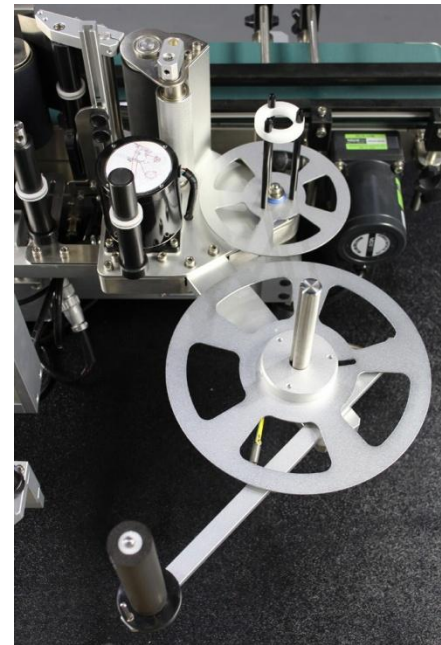

OPENED



CLOSED



BASE PAPER COLLECTOR

- 7. Remove the collector cap on the base paper collector and wind the base paper through the collector rods. Then reinstall the collector cap to secure the collector rods and ensure proper pickup tension.

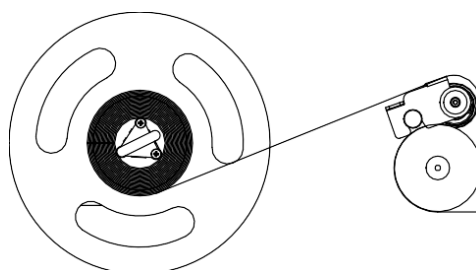

SENSITIVITY ADJUSTING OF LABEL SENSOR

1. Remove a label from the backing substrate before the sensor.
2. On the control panel, hold down "LENGTH SET" (Figure 1) until the backing substrate only is positioned in the sensor (Figure 2).
3. On the label sensor, hold down the "NORMAL" button until the green LED flashes and then turns solid (Figure 3).
4. Again, hold down "LENGTH SET" on the control panel until the next label is positioned in the sensor. If the sensor is setup correctly, the green and red LED will be on when a label is positioned in the sensor. Also, check the control panel and confirm that the counter for "LENGTH SET" is increasing and holding the count after you release the "LENGTH SET" button (Figure 4).
5. Lastly, position the next label to dispense no more than 3mm past the end of the peel plate.

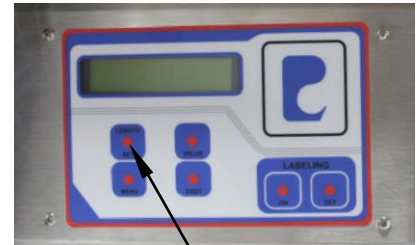

FIGURE 1 LENGTH SET



FIGURE 2



FIGURE 3



FIGURE 4

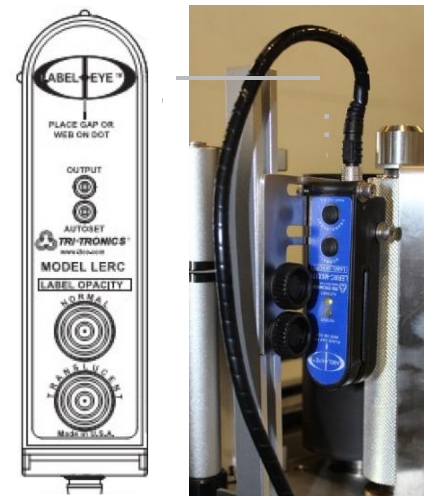

LABEL SENSOR

NOTE: This sensor cannot detect transparent labels.

NOTE: The status of the red LED and output transistors can be inverted by pressing both buttons simultaneously. When the output status has been inverted, the red LED and the output transistors will turn off when the label comes into view.

OBJECT SENSOR

The object sensor is a fiber optic infra-red sensor use to detect the presence of bottle on the labeling zone. If the sensor is not able to detect a bottle, adjust the intensity of the amplifier until the sensor is able to trigger the applicator to apply a label.

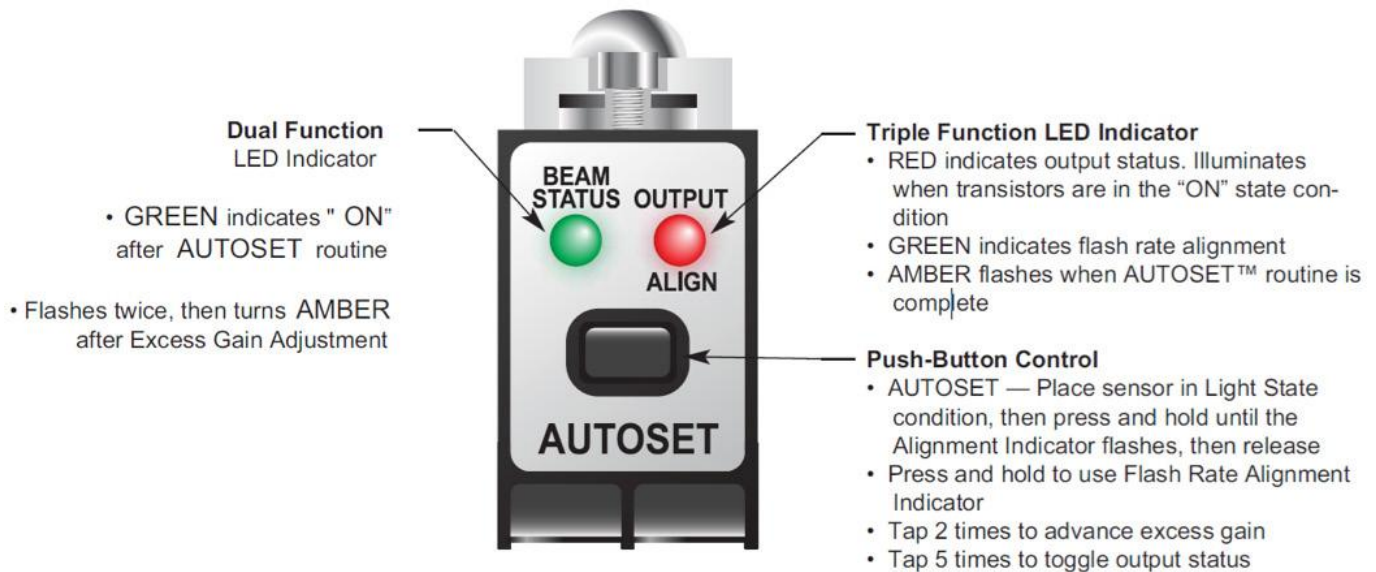

1. If sensor moves too far right, the label will come out too late and will not be applied to the bottle.
2. If sensor moves too far left, the label will come out too early and possibly cause vertical wrinkles.
3. The proper position of the sensor is to make sure the label is dispensed and applies to the apex of the bottles' surface.

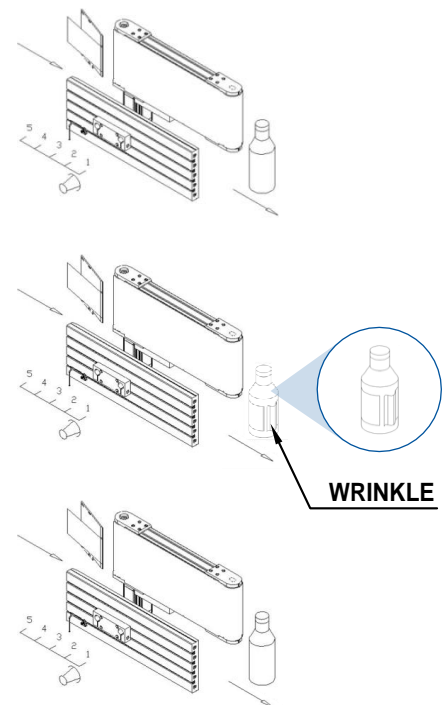

NOTE: The label position can be controlled through the control panel using the label position function.

PARTS ADJUSTMENTS

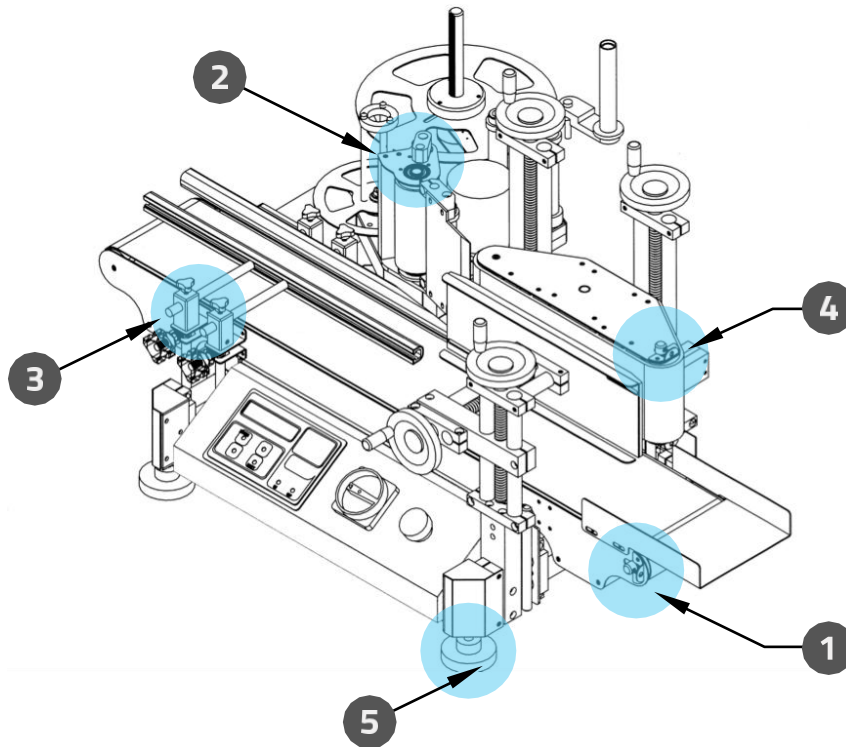

1

Conveyor adjustment: To adjust the tightness of the conveyor belt, turn the two screws. Turn counter clockwise to loosen and clockwise to tighten. Make sure the conveyor is centered. If not, it can cause the belt to wear prematurely.

2

Dispensing adjustment screw: If the label is skewing up or down all the time, loosen the four screws and adjust the dispensing plate upward if the label is skewing upward or vice versa and then tighten them up.

3

Guide rail adjustment screws: To adjust the width of the conveyor guides, loosen the knobs and adjust the position. Tighten after the desired width has been adjusted.

4

Wrap around belt adjustment: To adjust the tightness of wrap around belt, loosen the four screws and extend the pillar until the desired tightness is achieved and then tighten them up.

5

Conveyor height adjustment: Adjust the four footing screw to adjust conveyor to the appropriate height.

CONTROL PANEL

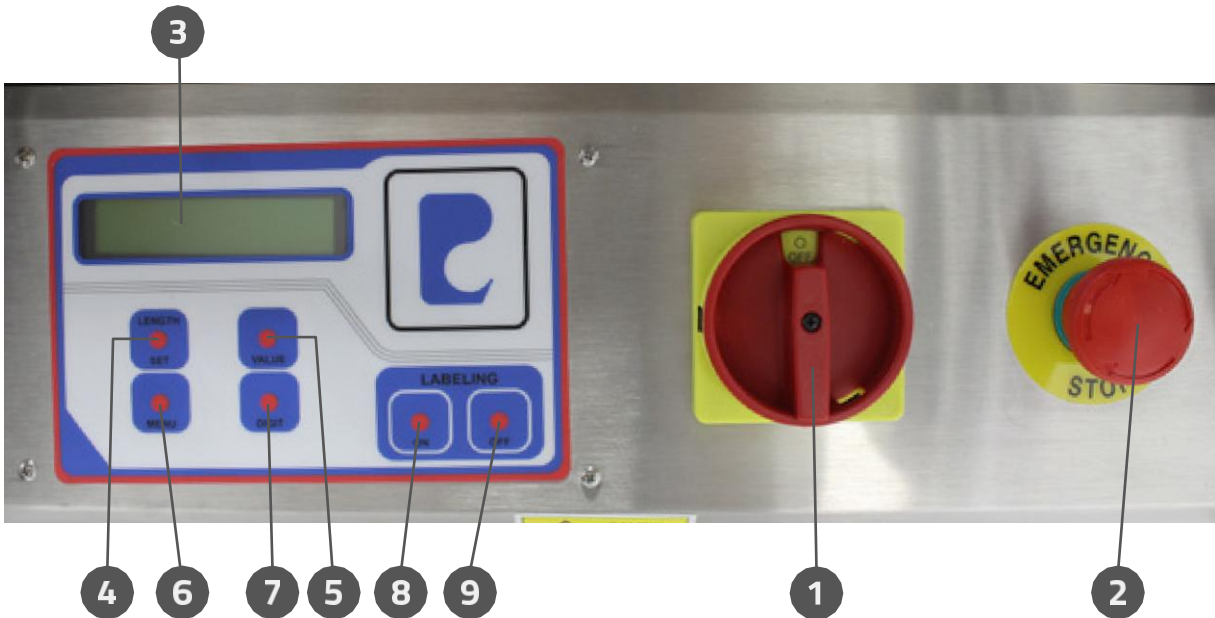

CONTROL PANEL LIST

NO.	DESCRIPTION	FUNCTION
1	Main PowerSwitch	Cut off or connect to main power supply
2	Emergency Switch	Emergency cutoff of power supply
3	Liquid Crystal Display	Displays the data
4	Length Sett	To set up the label length required
5	Value	To select the numeric value to be entered/on for printer
6	Menu	To exit and scroll the menu
7	Digit	To select the digits to be changed/off for printer
8	Labeling On	To stop conveyor and make settings changes
9	Labeling Off	To stop conveyor and make changes on setting



MACHINE OPERATION

MACHINE OPERATION

PLEASE FOLLOW STEPS AND INSTRUCTION BEFORE MACHINE OPERATION.

- 1 Connect machine to the appropriate power source and make sure the Emergency Stop is not engaged.
- 2 Machine adjusted to product specification range.
- 3 The height of label applicator adjusted in appropriate position.
- 5 Object sensor adjusted in right position.
- 6 Label Sensor is calibrated to the backing material.
- 7 Conveyor is clear with no extra object.
- 8 Wrap belt and pressure plate are adjusted to the product width so that the bottle spins when it enters the wrap station.

NOTE: Load label roll as per instruction of the label web sticker on the applicator or see page 10.

CONTROL PANEL SETUP

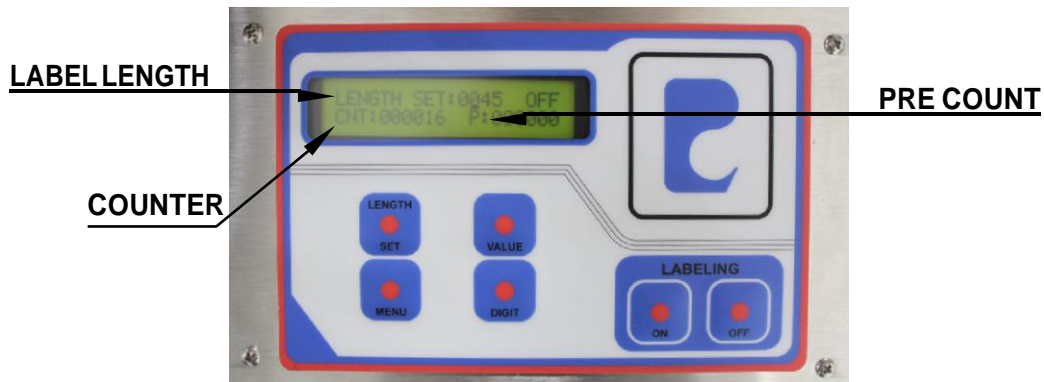

PRECOUNT SETUP

- 1 Press menu to select "PRECOUNT" and press "DIGIT" to select the digit then press "VALUE" to set the numbers.
- 2 Press "MENU" to exit.



LABEL DELAY SETUP

- 1 Use "MENU" to select "LABEL POSITION" to change the value of the delay.
- 2 Use "DIGIT" to select the digit that you want to set and press "VALUE" to select value. The higher number the longer the delay.



NOTE: The object sensor is set on delayed mode for wrap around so the "LABEL POSITION" function must be used to correct label placement.

- 3 When the "LABEL POSITION" is set to "00" the label applicator will dispense immediately.
- 4 Press "MENU" to exit.

CONTROL PANEL SETUP

LABEL HEAD SETUP

- 1 Press "VALUE" to turn the label head ON and press "DIGIT" to turn the label head OFF.



SPEED SETUP

- 1 Press "VALUE" to select speed 1-4.



PRINTER SETUP

- 1 Use "MENU" to select "PRINTER." Press "DIGIT" to turn "OFF" and press value to turn "ON." Press menu to exit.



MEMORY SETUP

- 1 Turn off "LABELING," Press "MENU" and select "MEMORY STORE" then select memory location by using "VALUE." Store the data by pressing "LABEL LENGTH." All parameters of label length, batch counter and delay will be stored into the assigned memory slot.



CONTROL PANEL

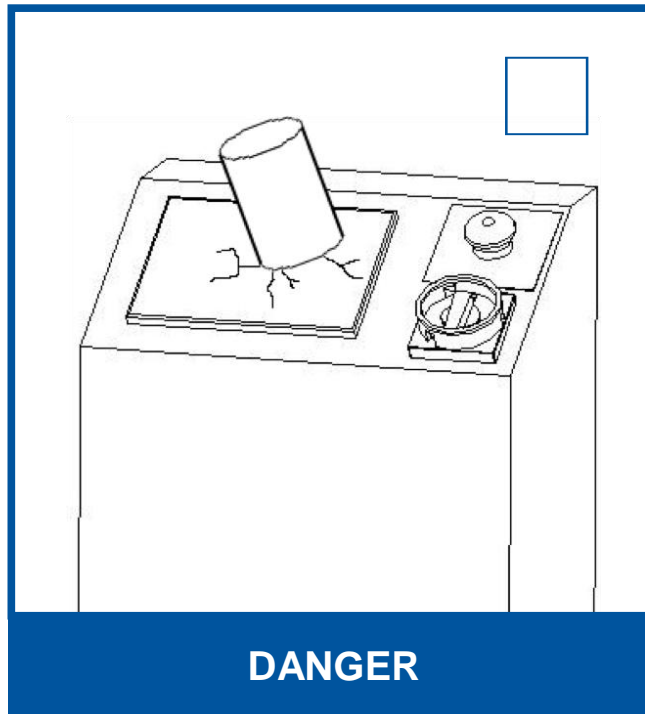

- Do not bump or press heavily on control panel.
- Lightly press on any point inside the control panel to input data.
- Lightly press buttons with a finger to select appropriate button (do not use a tool or sharp object).



- Use a soft cleaner or wet cloth to clean the surface of the control panel.
- Operators are not advised to open the control panel to change any spare parts. If so, we are not responsible for any of the damages or injuries.

TROUBLE SHOOTING

PROBLEM 1: LABEL LENGTH CANNOT BE SET

A. LABEL SENSOR WAS NOT ADJUSTED PROPERLY

1. Inspect the condition of the label sensor. Please refer to "Sensitivity adjusting instruction of label sensor" section.
2. If label length still cannot be set, replace the label sensor.

B. STEPPING MOTOR DOES NOT WORK

1. Inspect that the wires are properly connected. If the wires are not connected, please connect them and reset the labeling applicator.
2. If the problem is not in the wiring, please contact **Pack Leader**.

PROBLEM 2: MORE THAN ONE LABEL IS DISPENSED AT A TIME

A. SENSITIVITY OF LABEL SENSOR

1. The sensitivity of label sensor is too weak; as a result, the sensor cannot (or sometimes cannot) detect the label.
2. Reset the sensitivity of label sensor. (Refer to sensitivity adjusting instruction of label sensor)

B. LABEL LENGTH WAS SET TOO LONG

1. Please reset the label length.

PROBLEM 3: LABEL WON'T DISPENSE

A. OBJECT SENSOR RESPONSE

1. Inspect that the object sensor responds on the product. If not, adjust the sensitivity of the object sensor until the label comes out.
2. If the label still won't dispense by adjusting the object sensor, inspect the wire or replace with a new one.

B. THE "LABELING" ICON OF LABELING SET WAS NOT TURNED ON

1. Please Turn "On" the labeling set icon.

C. THE FUSE OF THE STEPPER MOTOR DRIVER IS BURNED OUT

1. Replace with a new fuse.

D. THE WIRE OF THE STEPPING MOTOR OR MOTOR DRIVER IS DAMAGED

1. Please notify maintenance technicians.

TROUBLE SHOOTING

PROBLEM 4: LABEL IS SLANTING

- A. BOTTLE IS NOT EVEN
- B. LABEL IS DIAGONALLY PLACED ON THE BASE PAPER WHEN THE LABELS ARE MADE
- C. THE SLANTING OCCURRED WHEN LABELING. THIS IS CAUSED WHEN THE PEEL PLATE IS NOT SQUARE TO THE PRODUCT.

NOTE 1: If problem is found in A or B, you need to improve the bottle or label.

NOTE 2: If the problem is found in C, you need to adjust the applicator peel plate to the appropriate position.

PROBLEM 5: NO SCREEN DISPLAY

- A. CHECK IF POWER IS TURNED ON
- B. CHECK IF THE CONNECTION WIRE IS NOT CONNECTED OR DAMAGED

PROBLEM 6: LABEL WILL NOT STICK ON THE PRODUCT

- A. LABEL COMES OUT TOO LATE
 1. Decrease the value of the label peel delay. If value is set to 0 move the physical location of the object sensor to the left.
- B. LABEL DOES NOT DISPENSE SMOOTHLY
 1. Check whether the PU drive roller with a lock in the label applicator is locked. If not, lock it. If labels still do not dispense smoothly when locked, check if PU drive roller is locked too tightly by turning the PU drive roller. If not, loosen the screw in the lock of the PU drive roller and adjust backwards slowly until it is tight enough when you lock it again.
- C. STEPPING MOTOR
 1. If stepping motor is not running properly, check the wires, belt and other spare parts to see if they are damaged.
 2. Replace stepping motor if defective.
- D. PRODUCT & LABEL
 1. Check whether the product surface is too wet or slippery or label has incorrect adhesive.

TROUBLE SHOOTING

PROBLEM 7: WRINKLES OR BUBBLE OCCUR WHEN LABELED

A. LABEL COMES OUT TOO EARLY

1. Move the object sensor left to an appropriate position to test labeling. If the label still comes out too early, move to step 2.
2. Increase the value of the label peel delay in LABELING MODE menu.

B. THE POSITION OF LABEL IS NOT ACCURATE

1. Check whether the front of the dispensing plate is square.
2. The label sensor is in an unusual position. Please inspect the label sensor or replace with a new one.
3. The gap between the labels are not consistent.

C. BOTTLE CONDITION

1. Surface of product is not consistent.

D. BACK PRESSURE PLATE

1. Back pressure plate is too tight

PROBLEM 8: CONVEYOR DOES NOT WORK

A. WILL NOT RESPOND ON THE TOUCH SCREEN

1. Please re-start the machine.
2. After restarting the machine, if the conveyor still does not work contact **Pack Leader USA**.

B. CONVEYOR MOTOR

1. Gearwheel belt is damaged or loose.
2. Check wires for damage.



ELECTRONIC PANEL

ELECTRONIC DIAGRAM

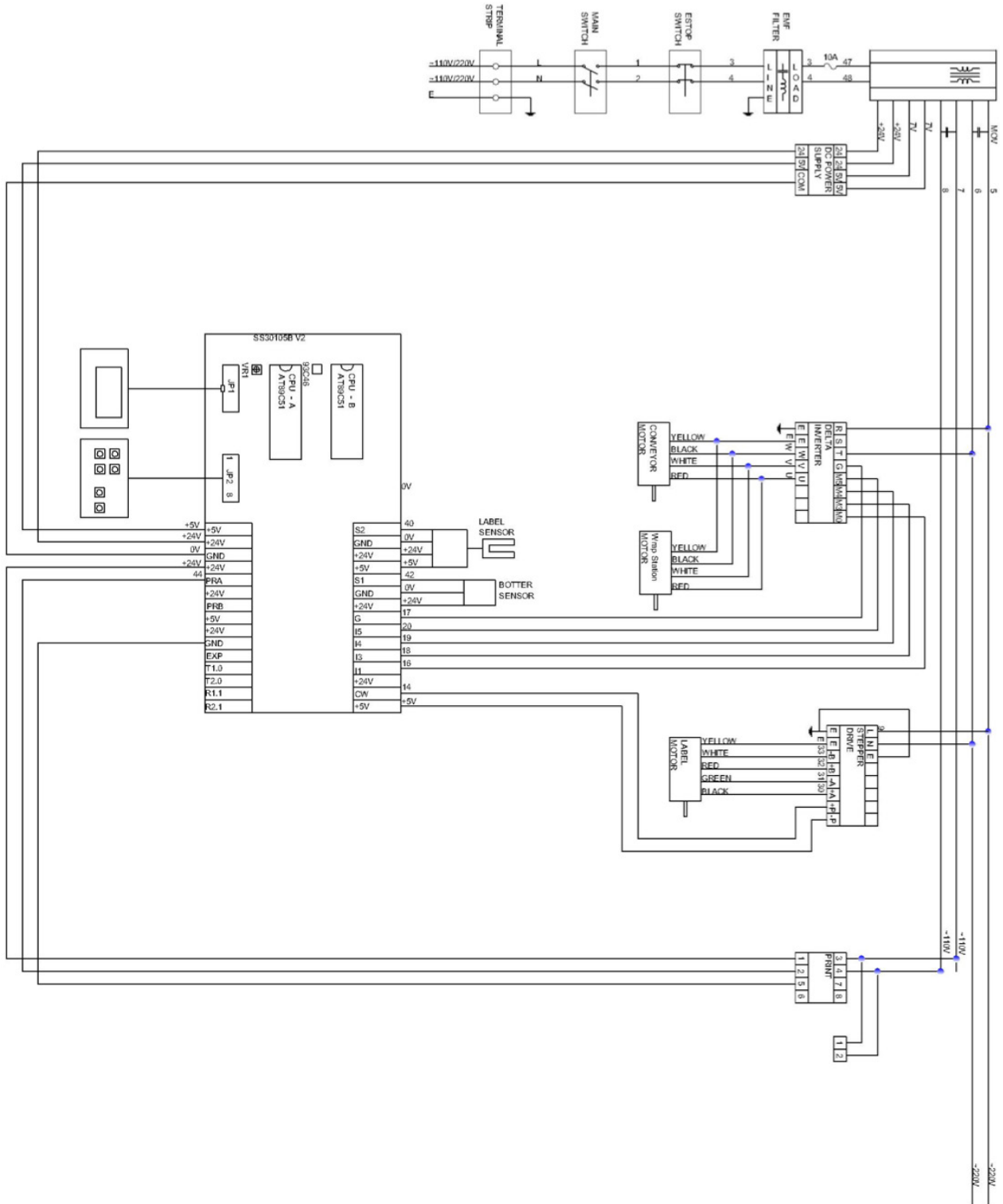

CONTROL BOX FRAME

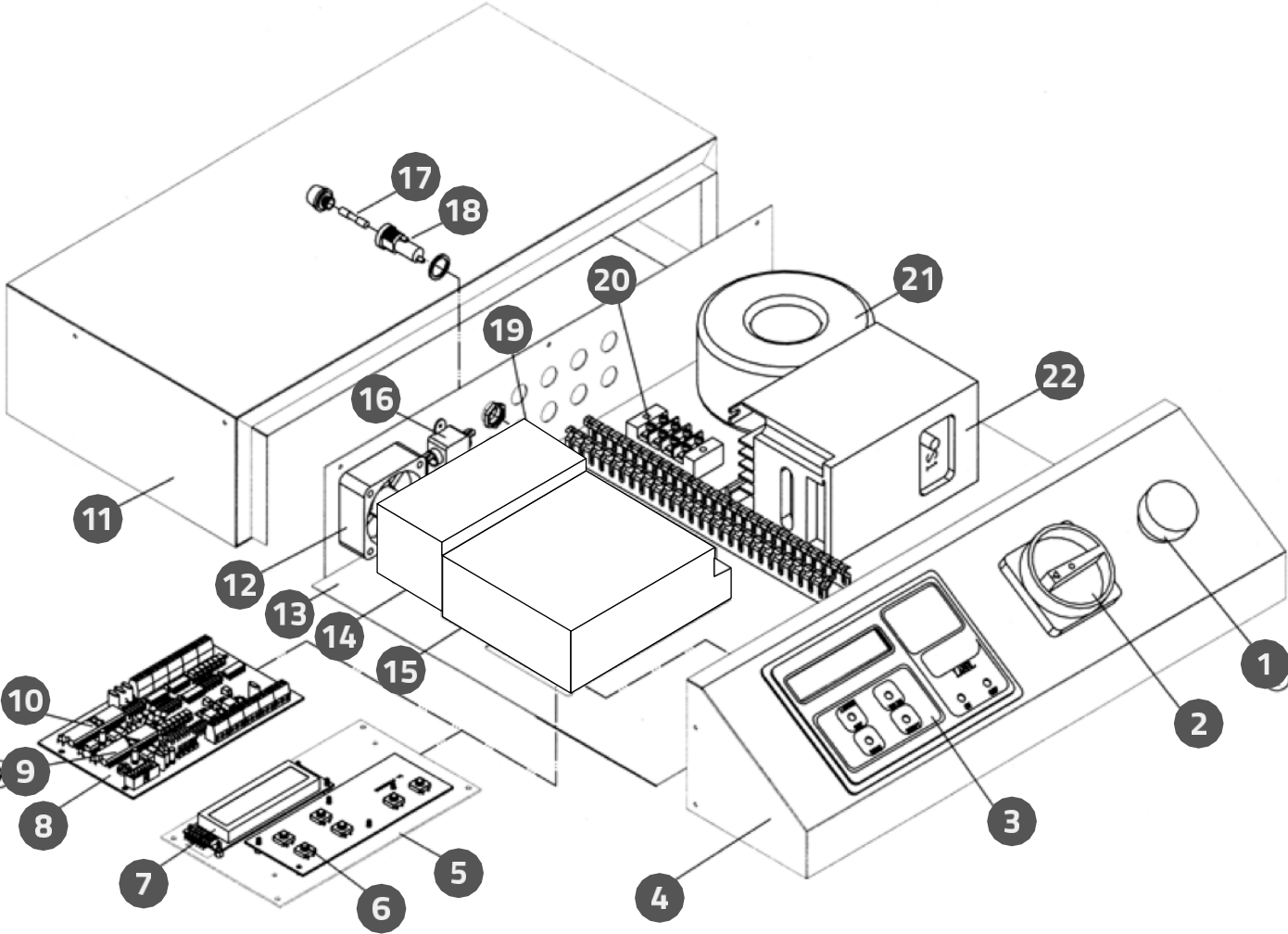

CONTROL BOX FRAME PARTS LIST

NO.	DESCRIPTION	PARTS NO.	QTY.
1	Emergency Cutoff Switch	C-1403	1
2	Main Switch	C-1400	1
3	Panel Sticker	2Y1F-ELFCS0010	1
4	Front Panel	CS1-ELF-002	1
5	Push Button Assembly	CS1-ELF-004	1
6	Push Button	2YPCB-SS30326A	1
7	LCD Display	C-1040	1
8	PC Board	2YPCB-SS30105B	1
9	IC Chip A	2YIC-89S5124AT	1
10	IC Chip B	2YIC-89C51	1
11	Top Cover	CS1-ELF-003	1
12	Exhaust Fan	2Y2G-KD2406PTB1	1
13	Base Cover	CS1-ELF-001B	1
14	Power Supply Fabrication	2YE2-RD35B	1
15	2 Phase Stepper Driver DA2D20B	2YF2-DA2D20B	1
16	EMI Filter	2YXQF-20A250VAC	1
17	Fuse 10A	C-1708	1
18	Seat Of Fuse	E-0160	1
19	Copper Ingot	C-1800	1
20	Terminals 4 Pin	C-1508	1
21	Transformer	2Y1U-2301104C	1
22	Inverter VF002S23A	2Y1Q-VF002S23A	1



APPLICATOR

APPLICATOR EXPLODED VIEW

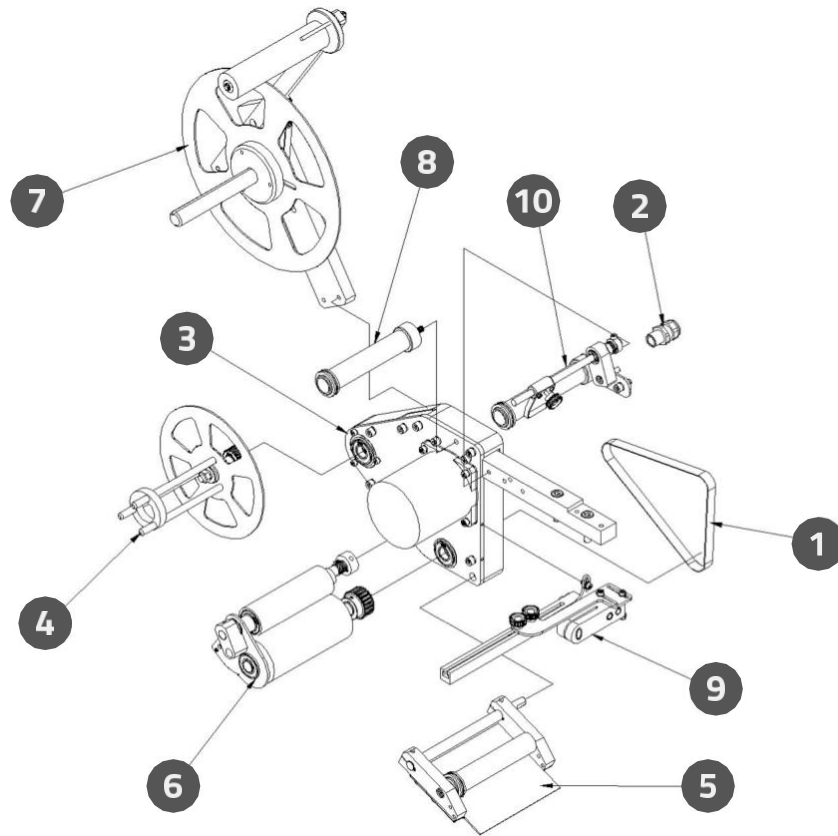

APPLICATOR EXPLODED VIEW PART LIST

NO.	DESCRIPTION	PARTS NO.	QTY.
1	Timing Belt200XL050	T2Q2-200XL050	1
2	Cable Connector	QVQR-MG16A-10B	1
3	Applicator Motor Assembly	See page30	1
4	Base Paper Collect Assembly	See page32	1
5	Label Peel Plate Assembly	ELF1050501	1
6	Applicator Driving Assembly	See page34	1
7	Label Supply Plate Assembly	See page39	1
8	Label Roller Assembly	See page41	1
9	Label Sensor Base Assembly	See page42	1
10	Label Load Assembly (Without Printer)	See page43	1

APPLICATOR MOTOR ASSEMBLY

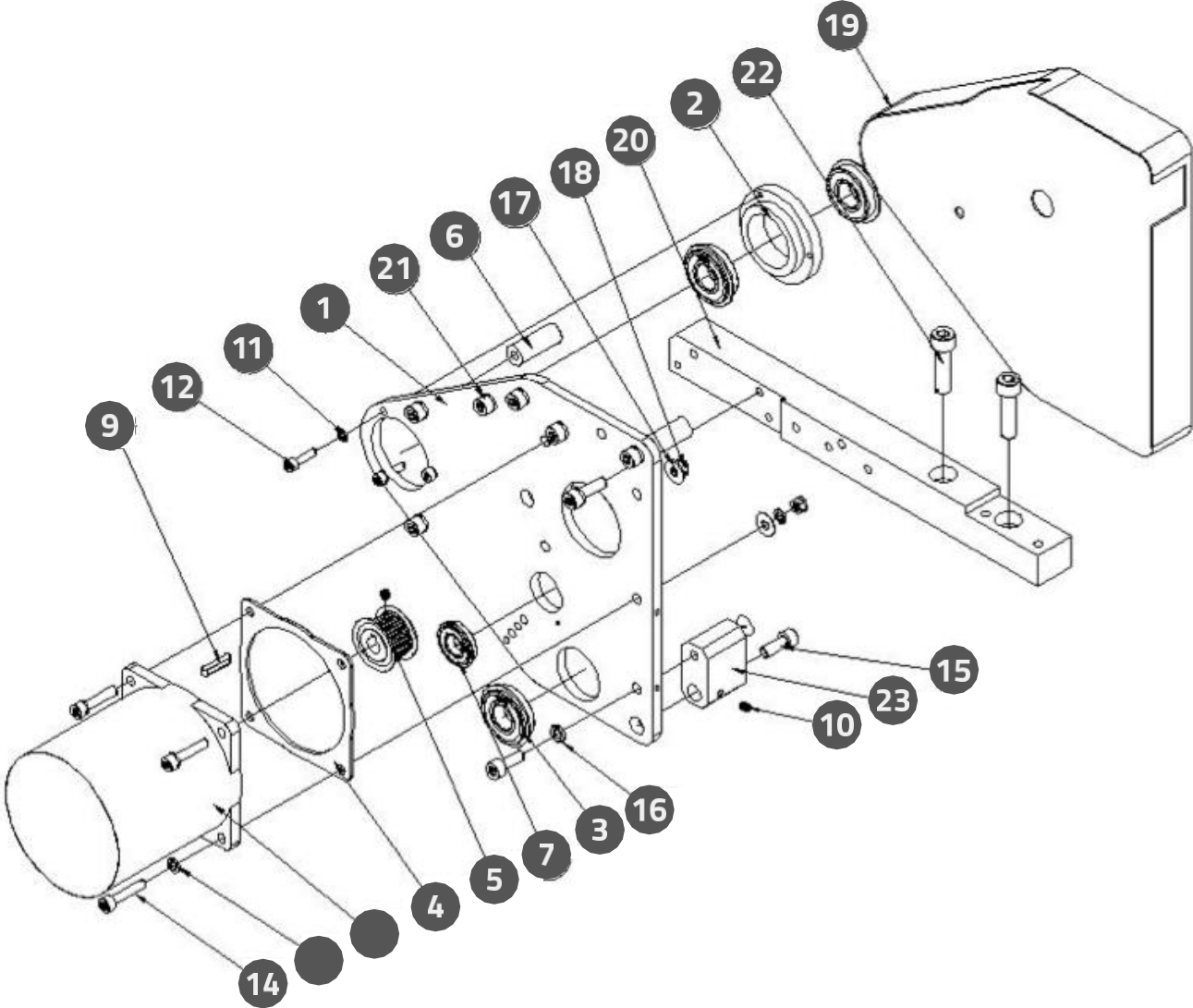

APPLICATOR MOTOR ASSEMBLY PART LIST

NO.	DESCRIPTION	PARTS NO.	QTY.
1	Applicator Base Plate	ELF1050501-001	1
2	PU Roller Bearing Seat	LA1-ELF-021	1
3	Bearing 6002NR	5TGH-6002NR	3
4	Pad Of Stepper Motor	LA1-ELF-023	1
5	Motor Gear	LA1-ELF-040	1
6	Spacing Rod	LA1-ELF-022	3
7	Bearing 6901NR	5TGH-6901NR	1
8	Stepper Motor	A21R-DA29902H8	1
9	Double Head Round Keys	RGM-4420	1
10	Socket Set Screw	XN5Z-M45	2
11	Spring Washer-M4	2FWO-M4	3
12	Socket Head Cap Screws	XNJW-M416	3
13	Spring Washer-M6	2FWO-M5	6
14	Socket Head Cap Screws	XNJW-M525	4
15	Socket Head Cap Screws	XNJW-M616	5
16	Spring Washer-M6	2FWO-M6	8
17	Washer-M5	XNQC-M5	2
18	Nut-M5	XAXR-M5	2
19	Back Cover	ELF1050501-002	1
20	Main Rod	ELF1050501-017	1
21	Socket Head Cap Screws	XNJW-M620	4
22	Socket Head Cap Screws	XNJW-M830	2
23	Spacing Block	ELF1050501-032	1

BASE PAPER COLLECT ASSEMBLY

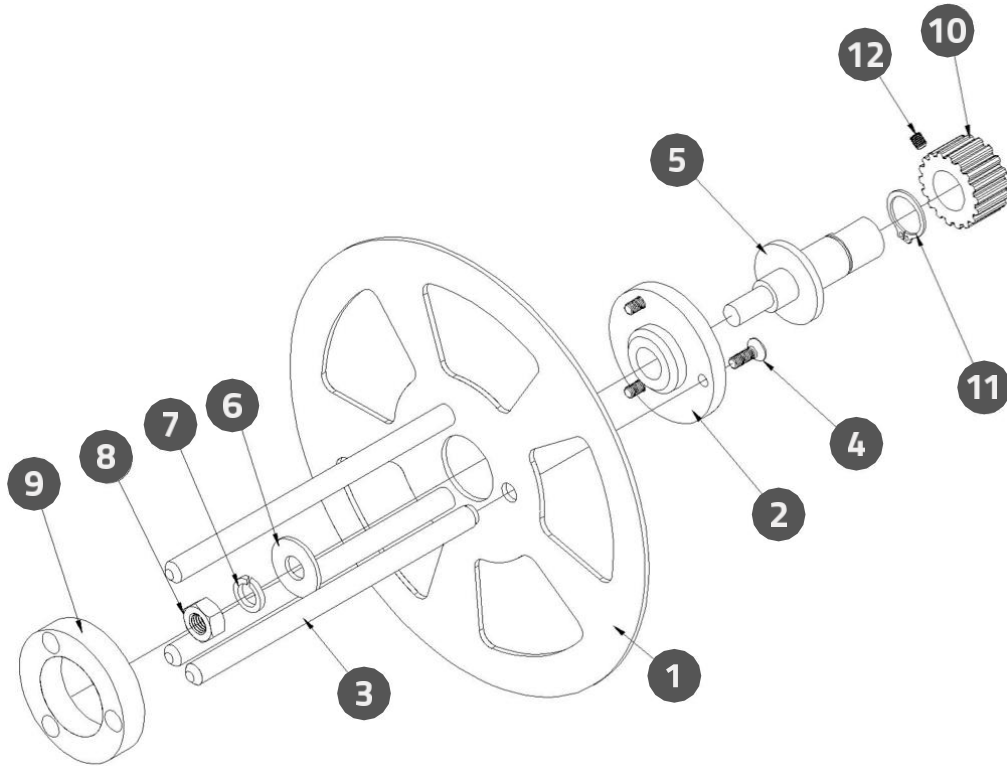

BASE PAPER COLLECT ASSEMBLY PART LIST

NO.	DESCRIPTION	PARTS NO.	QTY.
1	Paper CollectPlate	LA1-ELF-018	1
2	Paper CollectBase	LA1-ELF-017	1
3	Collector Rods	LA1-ELF-019	3
4	Philips HeadScrews	XNMW-M415	3
5	Paper CollectShaft	LA1-ELF-020	1
6	Washer	XNQC-M8	1
7	Spring Washer	2FWO-M8	1
8	Screw Nut	XAXR-M8S	1
9	Collector Cap	LA1-ELF-039	1
10	Collector Gear	LA1-ELF-041	1
11	S-Ring S15	DCSV-S15	1
12	Socket SetScrew	XN5Z-M45	1

LABEL PEEL PLATE ASSEMBLY

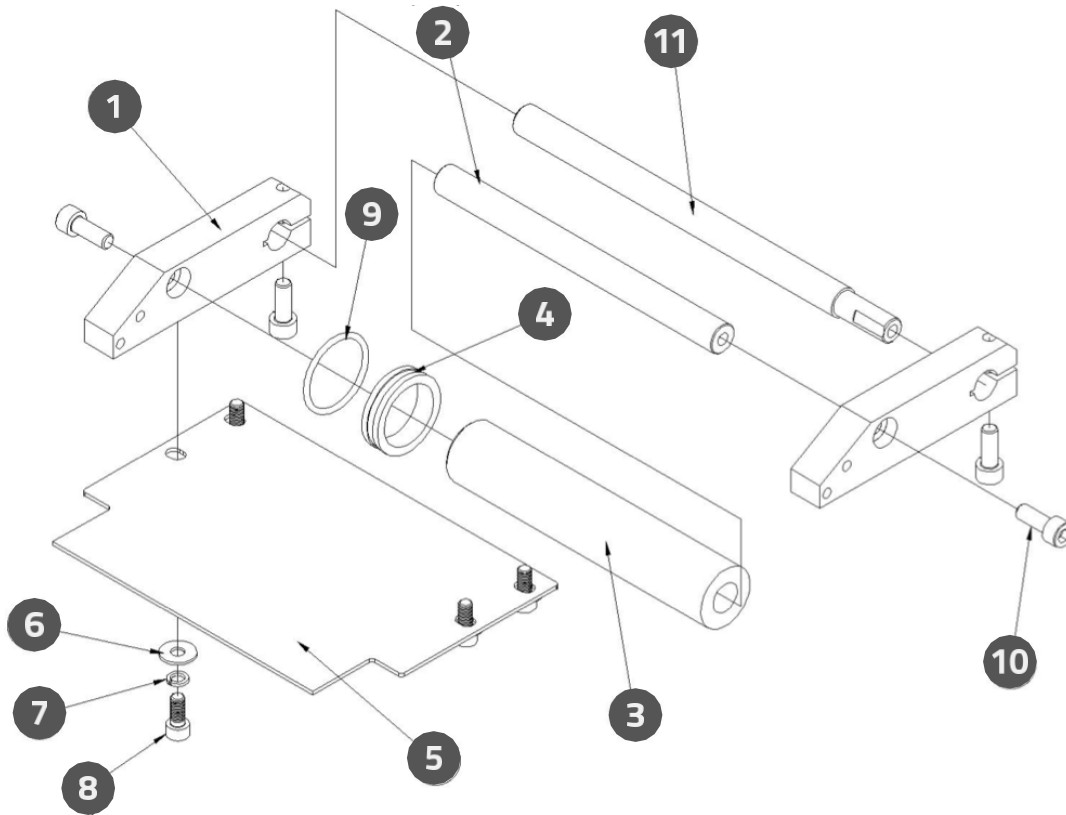

LABEL PEEL PLATE ASSEMBLY PART LIST

NO.	DESCRIPTION	PARTS NO.	QTY.
1	Dispenser Base	ELF1050501-004B	2
2	Dispenser Fixing Shaft	LA1-ELF-011	1
3	Label Roller	LA1-ELF-013	1
4	Label Roller Sleeve	LA1-ELF-038B	1
5	Dispenser Plate	ELF1050501-005	1
6	Washer	XNQC-M5	4
7	Spring Washer	2FWO-M5	4
8	Socket Head Cap Screws	XNJW-M512	4
9	Spring	LA1-PL150-052	1
10	Socket Head Cap Screws	XNJW-M616	4
11	Peel Plate Rod	ELF1050501-003B	1

APPLICATOR DRIVING ASSEMBLY

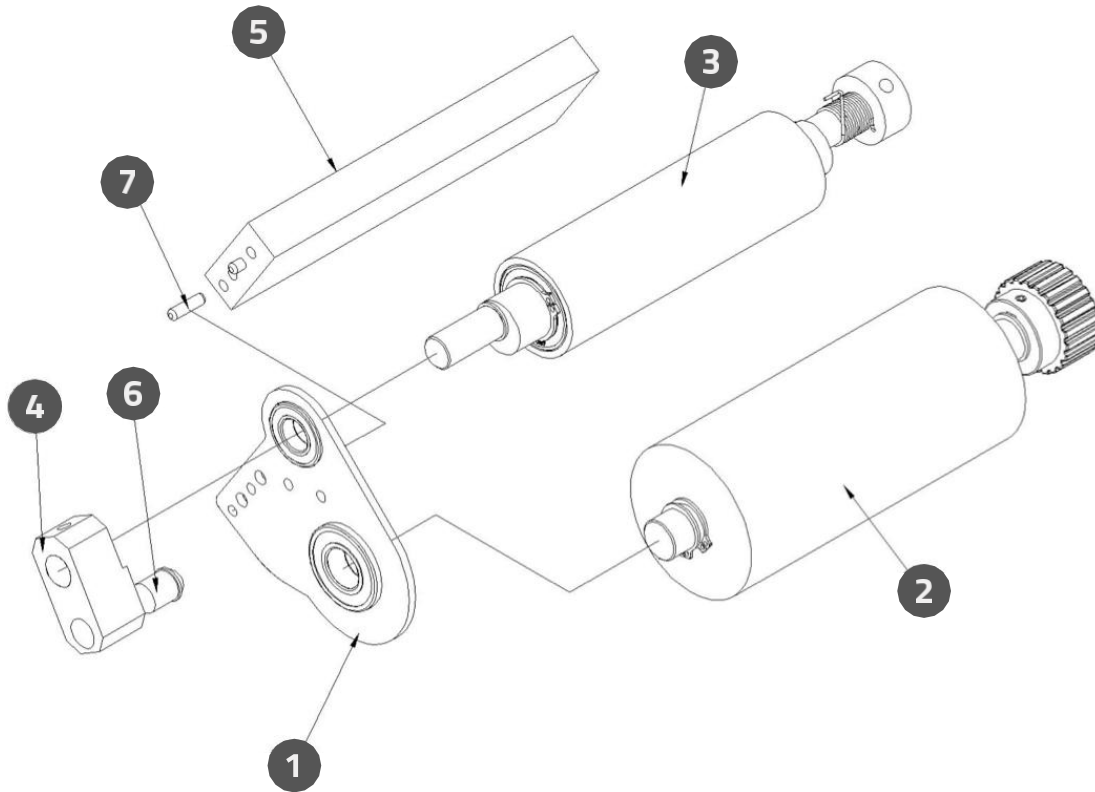

APPLICATOR DRIVING ASSEMBLY PART LIST

NO.	DESCRIPTION	PARTS NO.	QTY.
1	Bearing Seat Fixing Plate Assembly	See page 35	1
2	PU Roller Assembly	See page 36	1
3	Aluminum Knurled Roller Assembly	See page 38	1
4	Aluminum Knurled Roller Lever	LA1-ELF-009	1
5	Aluminum Block Mount	LA1-ELF-006C	1
6	Ball Plunger	51WR-9.5	1
7	Position pin	51WR-MSSC0415	2

BEARING SEAT FIXING PLATE ASSEMBLY

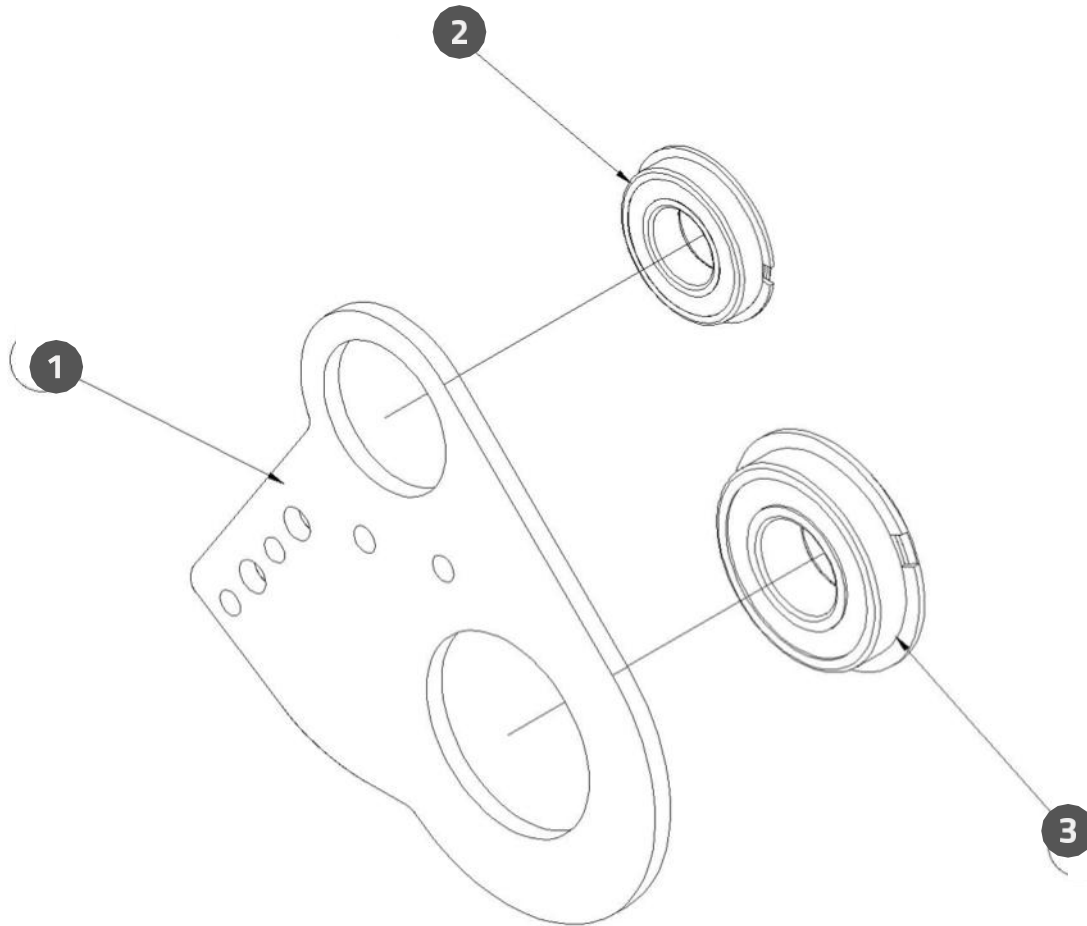

BEARING SEAT FIXING PLATE ASSEMBLY PART LIST

NO.	DESCRIPTION	PARTS NO.	QTY.
1	Bearing Seat Fixing Plate	ELF1050501-009	1
2	Bearing	5TGH-6901NR	1
3	Bearing	5TGH-6901NR	1

PU ROLLER ASSEMBLY

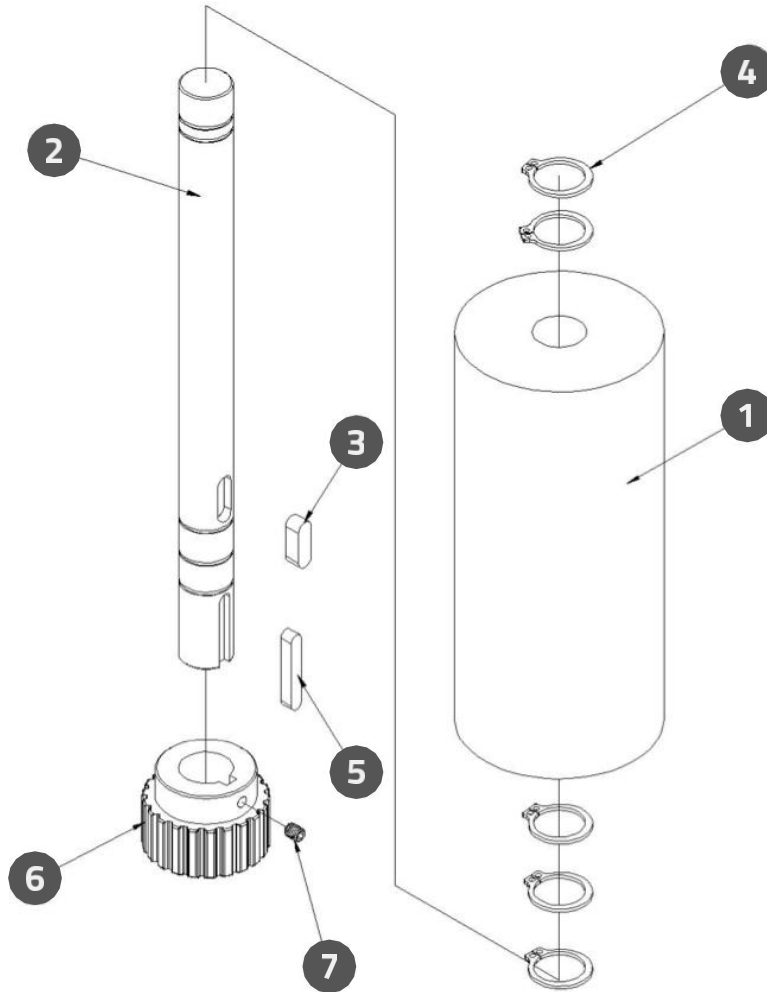

PU ROLLER ASSEMBLY PART LIST

NO.	DESCRIPTION	PARTS NO.	QTY.
1	PU Roller	LA1-ELF-005	1
2	Roller Shaft	ELF1050501-007B	1
3	Bearing 6002NR	RGM-5515	1
4	S-Ring S15	DCSV-S15	5
5	Double Head Round Keys	RGM-4425	1
6	Pulley of PU Roller	T2Q2X-22XL050154	1
7	Socket Assembly Screw	XN5Z-M45	1

ALUMINUM KNURLED ROLLER ASSEMBLY

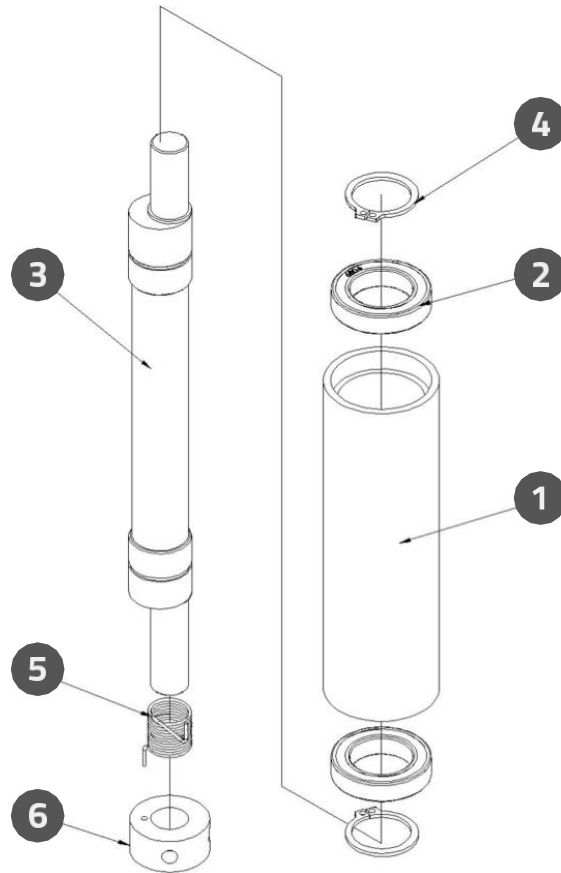

ALUMINUM KNURLED ROLLER ASSEMBLY PART LIST

NO.	DESCRIPTION	PARTS NO.	QTY.
1	Aluminum Knurled Roller	LA1-ELF-007	1
2	Bearing 6804ZZ	5TGH-6804ZZ	2
3	Aluminum Knurled Roller Shaft	ELF1050501-008	1
4	S-Ring	DCSV-S20	2
5	Spring of Tension Bar	LA1-ELF-024	1
6	Spring Seat	LA1-ELF-025	1

LABEL SUPPLY ASSEMBLY

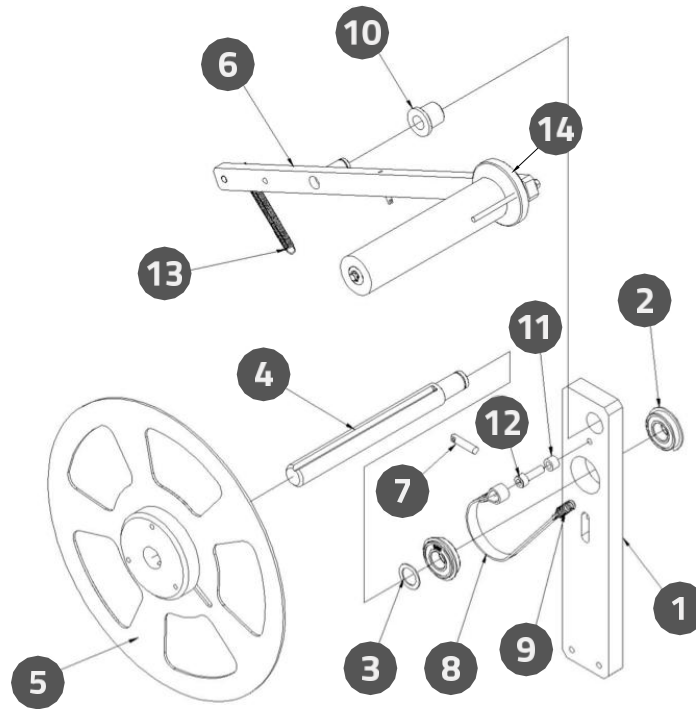

LABEL SUPPLY ASSEMBLY PART LIST

NO.	DESCRIPTION	PARTS NO.	QTY.
1	Feeding Tray Base	ELF1050501-010	1
2	Bearing	5TGH-6002NR	2
3	Feeding Shaft Pad	ELF1050501-012	1
4	Feeding Tray Shaft	ELF1050501-011	1
5	Label Supply Plate Assembly	See page 39	1
6	Tension Bar Assembly	ELF1050501	1
7	Pillar	51WR-SWIPOZ0625	1
8	Brake Belt	ELF1050501-027	1
9	Spring	51WC-WUT8-30	1
10	Self Run Bearing	AFM-1218-20	1
11	Brake Belt Block	ELF1050501-026	1
12	Socket Head Cap Screws	XNJW-M620	1
13	Spring	51WC-WUY8-70	1
14	Tension Bar Assembly	See page 40	1

LABEL SUPPLY PLATE ASSEMBLY

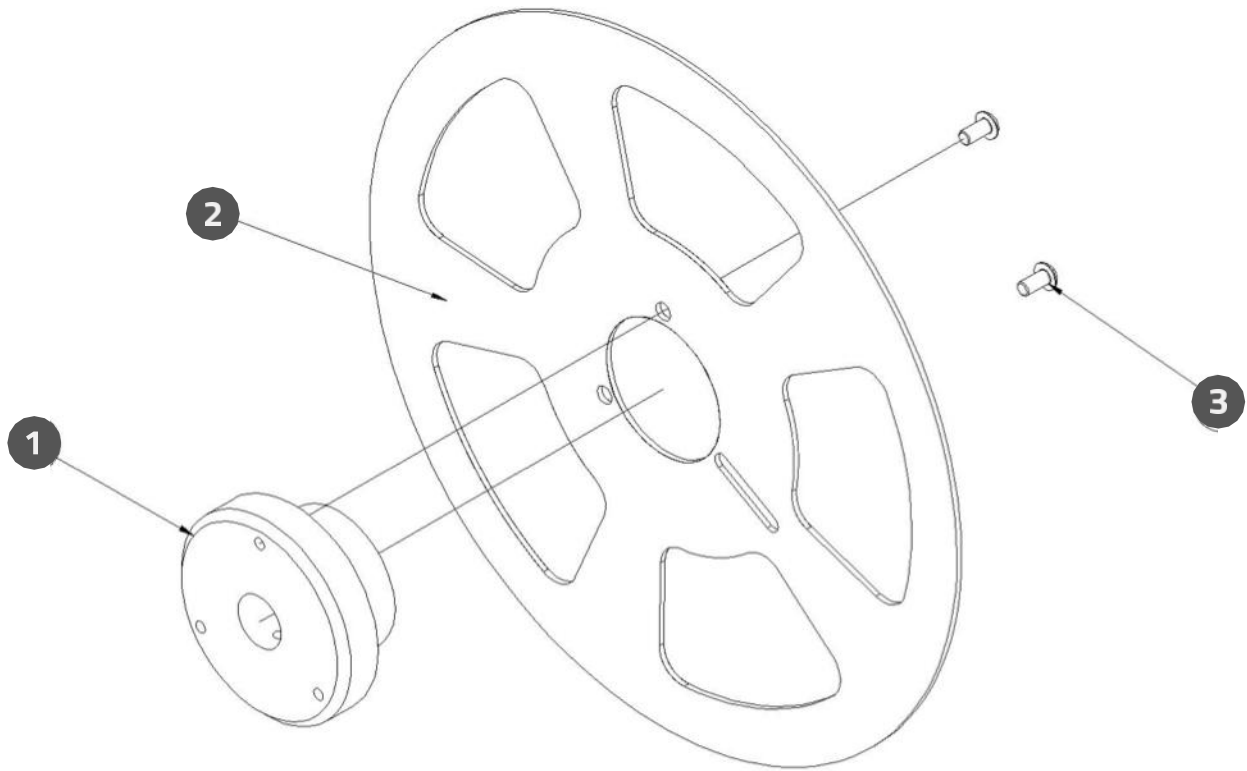

LABEL SUPPLY PLATE ASSEMBLY PART LIST

NO.	DESCRIPTION	PARTS NO.	QTY.
1	Lock Block	ELF1050501-013B	1
2	Label FeedTray	LA1-ELF-033	1
3	Socket Button Head Cap Screws	XN1M-M516	2

TENSION BAR ASSEMBLY

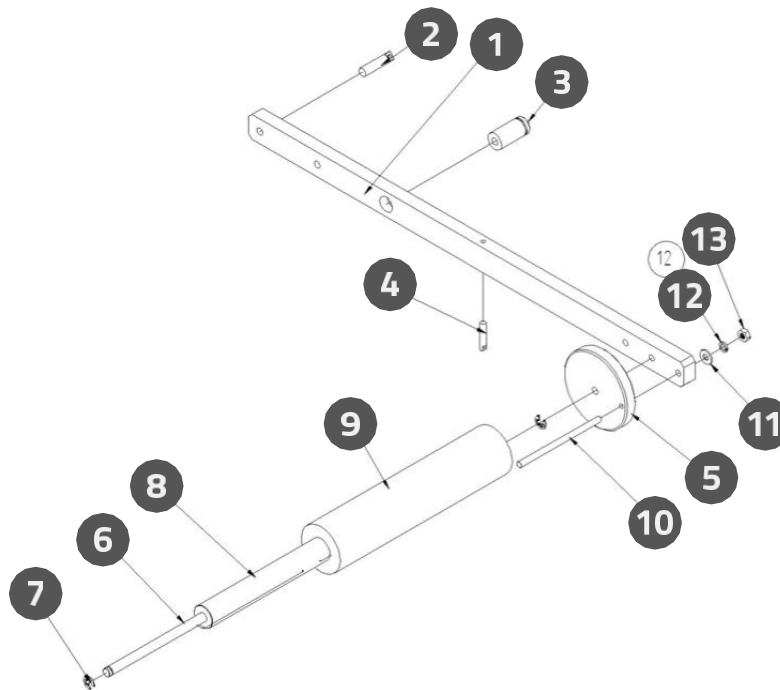

TENSION BAR ASSEMBLY PART LIST

NO.	DESCRIPTION	PARTS NO.	QTY.
1	Tension Bar	ELF1050501-014	1
2	Spring Rod	51WR-SWIPOZ0625	1
3	Tension Bar Rotating Shaft	ELF1050501-016	1
4	Spring Rod	51WR-SWIPOZ0420	1
5	Tension Bar Pad	ELF1050501-015	1
6	Roller Shaft of Tension Bar	LA1-PL150-065	1
7	E-Ring E4	DCEV-E4	2
8	Interior Roller Of Tension Bar	LA1-PL150-066	1
9	Exterior Roller Of Tension Bar	LA1-PL150-067	1
10	Shaft	LA1-PL150-087B	1
11	Washer	XNQC-M4	1
12	Spring Washer	2FWO-M4	1
13	Screw Nut	XAXR-M4	1

LABEL ROLLER ASSEMBLY

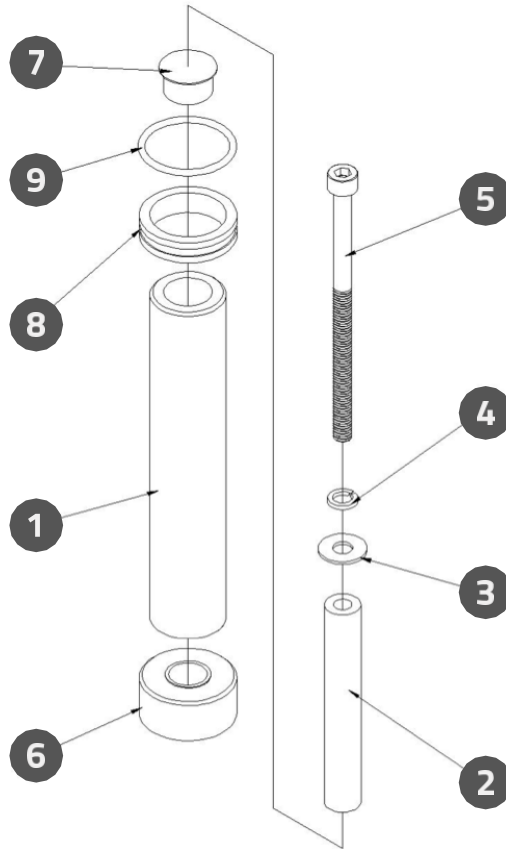

LABEL ROLLER ASSEMBLY PART LIST

NO.	DESCRIPTION	PARTS NO.	QTY.
1	Label Roller	LA1-ELF-013	1
2	Roller Shaft of Label Orientation	LA1-ELF-016B	1
3	Washer-M6	XNQC-M6	1
4	Spring Washer-M6	2FWO-M6	1
5	Socket Head Cap Screws	XNJW-M6100	1
6	Label Roller Sleeve (Large)	LA1-PL150-019	1
7	Plug	QVDG-HP16	1
8	Label Roller Sleeve	LA1-ELF-038B	1
9	Spring	LA1-PL150-052	1

LABEL SENSOR BASE ASSEMBLY

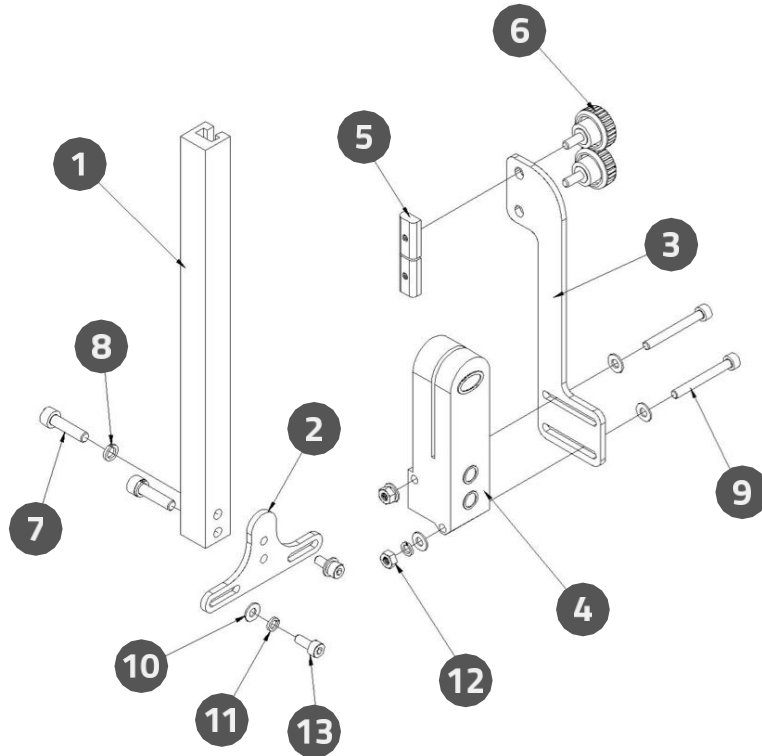

LABEL SENSOR BASE ASSEMBLY PART LIST

NO.	DESCRIPTION	PARTS NO.	QTY.
1	Sensor Adjusted Bar	LA1-PL150-077D	1
2	Sensor Adjusted Pad	ELF1050501-020	1
3	Sensor Locking Pad	ELF1050501-021B	1
4	LERRC Label Sensor	2YE2-LERRCM8171	1
5	Square Nut	XAZV-NSM4	2
6	Stainless Steel Knob	51WR-802020M410	2
7	Socket Head Cap Screws	XNJW-M520	2
8	Spring Washer-M5	2FWO-M5	2
9	Socket Head Cap Screws	XNJW-M435	2
10	Washer-M4	XNQC-M4	6
11	Spring Washer-M4	2FWO-M4	4
12	Nut-M4	XAXR-M4	2
13	Socket Head Cap Screws	XNJW-M410	2

LABEL LOAD ASSEMBLY (WITHOUT PRINTER)

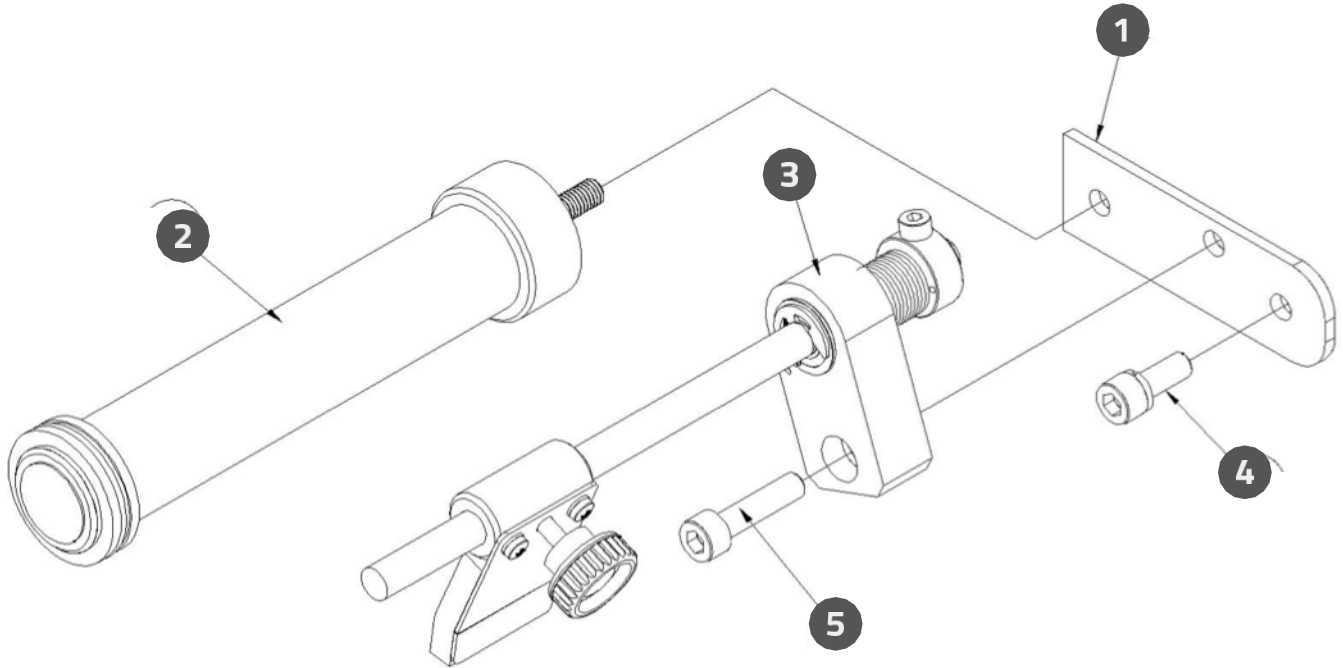

LABEL LOAD ASSEMBLY (WITHOUT PRINTER) PART LIST

NO.	DESCRIPTION	PARTS NO.	QTY.
1	Roller Pad	ELF1050501-019	1
2	Press Roller Assembly	See page45	1
3	Paper Press Assembly	See page44	1
4	Socket Head Cap Screws	XNJW-M616	1
5	Socket Head Cap Screws	XNJW-M625	1

LABEL PRESS ASSEMBLY

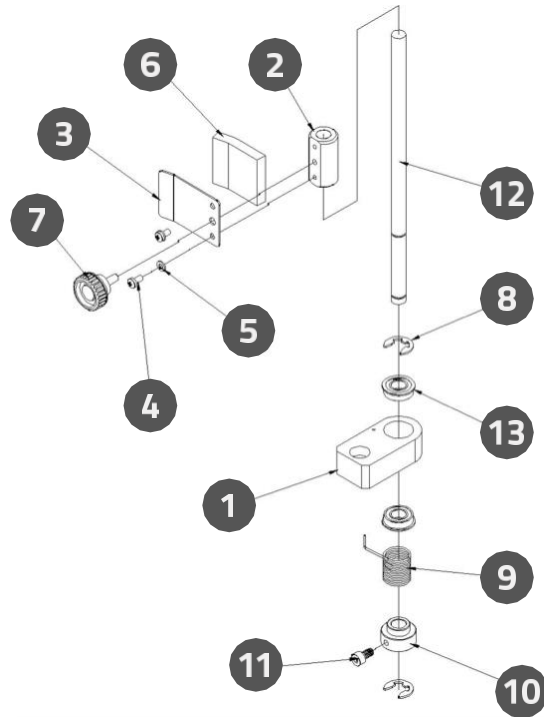

LABEL PRESS ASSEMBLY PART LIST

NO.	DESCRIPTION	PARTS NO.	QTY.
1	Label Press Plate Bracket	LA1-ELF-044	1
2	Label Press Plate Base	LA1-PL150-046	1
3	Label PressPlate	LA1-PL150-037	1
4	Philips HeadScrews	XNMW-M35	2
5	Spring Washer	2FWO-M3	2
6	Label PressPad	LA1-PL150-089	1
7	Knob 802020M410	51WR-802020M410	1
8	E-Ring E8	DCEV-E8	2
9	Spring	LA1-PL150-101	1
10	Spring Base	LA1-PL150-017	1
11	Socket Head Cap Screws	XNJW-M48	1
12	Label Press Shaft	LA1-ELF-045B	1
13	Bearing	5TGH-F688ZZ	2

LABEL PRESS ROLLER ASSEMBLY

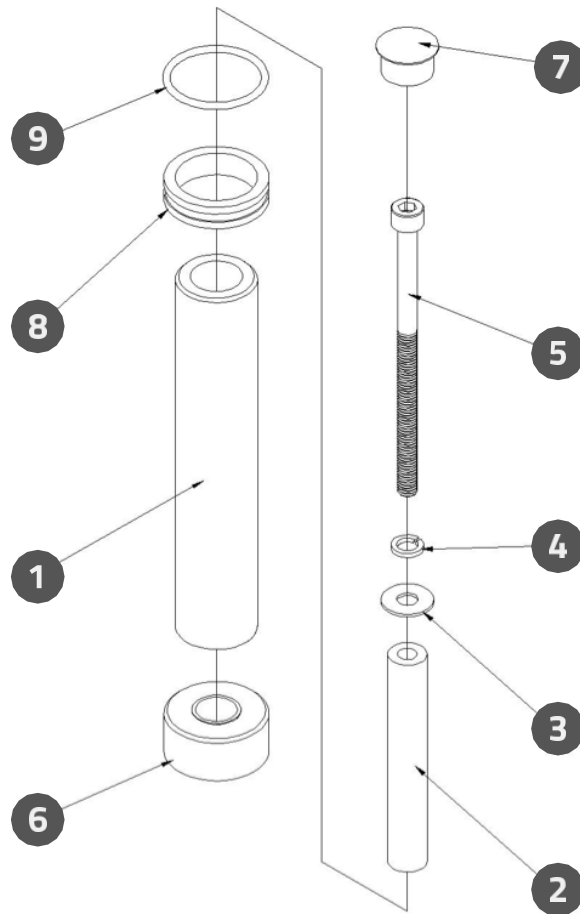

LABEL PRESS ROLLER ASSEMBLY PART LIST

NO.	DESCRIPTION	PARTS NO.	QTY.
1	Label Roller	LA1-ELF-013	1
2	Roller Shaft of Label Orientation	LA1-ELF-048B	1
3	Washer-M6	XNQC-M6	1
4	Spring Washer-M6	2FWO-M6	1
5	Socket Head Cap Screws	XNJW-M6100	1
6	Label Roller Sleeve (Large)	LA1-PL150-019	1
7	Plug	QVDG-HP16	1
8	Label Roller Sleeve	LA1-ELF-038B	1
9	Spring	LA1-PL150-052	1

APPLICATOR ADJUSTMENT ASSEMBLY

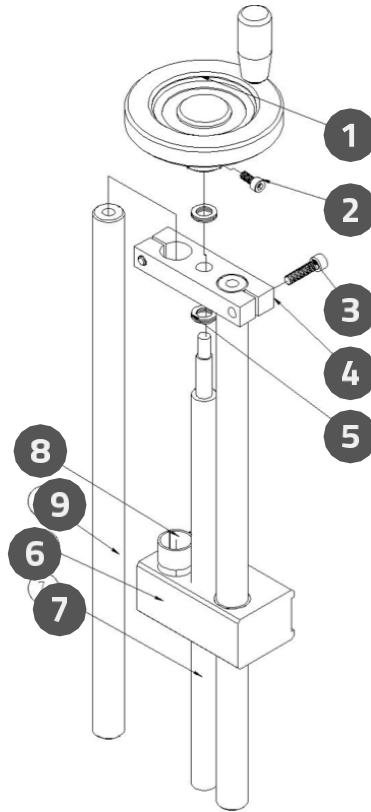

APPLICATOR ADJUSTMENT ASSEMBLY PART LIST

NO.	DESCRIPTION	PARTS NO.	QTY.
1	Hand Wheel	QRGX-KRA100CB65	1
2	Socket Head Cap Screws	XNJW-M512	2
3	Socket Head Cap Screws	XNJW-M625	2
4	Mounting Base of Hand Wheel	AA1-ELF-014	1
5	Nylon Washer	2FN2-101610	6
6	Applicator Adjustment Base	ELF1050501-024	1
7	Screw Rod	AA1-ELF-007	1
8	Self Run Bearing	5TDU-LBF2015	4
9	Sliding Shaft D20400	AA1-ELF-004	2

LEADER USA

leaderusa.com



WRAP STATION

WRAP STATION ASSEMBLY

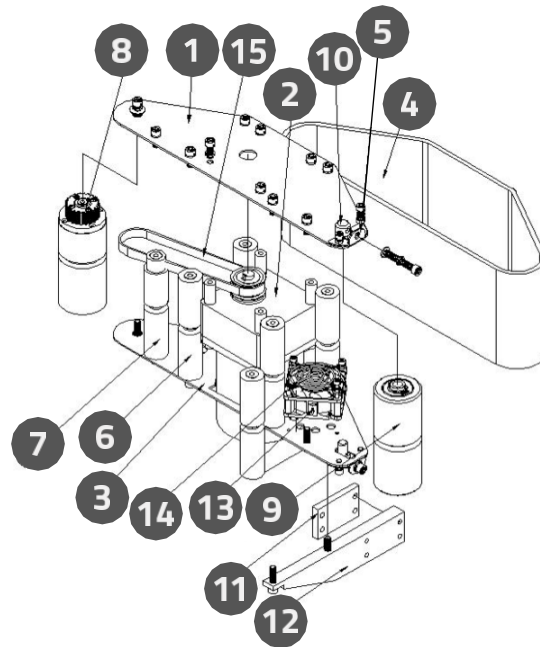

WRAP STATION ASSEMBLY PART LIST

NO.	DESCRIPTION	PARTS NO.	QTY.
1	Upper BasePlate	WB1-ELF-001B	1
2	Wrap Station Motor Assembly	See page49	1
3	Lower BasePlate	WB1-ELF-002C	1
4	Wrap Around Belt 120W*800L	T2EW-120W800L	1
5	Driven Pulley Adjustment Plate	CV1-ELF-008	2
6	Space Roller Assembly 1	See page52	5
7	Space Roller Assembly 2	See page53	1
8	Wrap Station Driving Pulley Assembly	See page50	1
9	Wrap Station Driven Pulley Assembly	See page51	1
10	Driven Pulley Adjust Block	CV1-ELF-009	2
11	SupporterBase Pad	WB1-ELF-012	2
12	Wrap StationSupporter	WB1-ELF-011	2
13	Fan	2Y2G-QZG-MGAC24V*6025HB	1
14	Fan Cover	2Y2G-SF06	1
15	Gear Belt	T2Q2-148XL050	1

WRAP STATION MOTOR ASSEMBLY

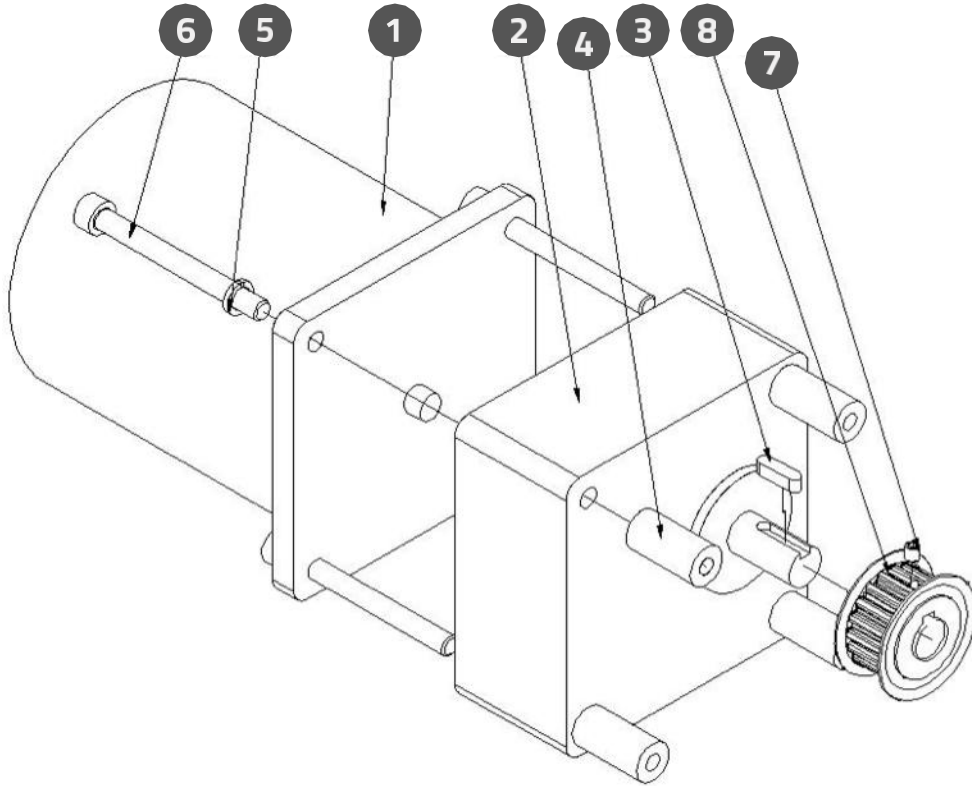

WRAP STATION MOTOR ASSEMBLY PART LIST

NO.	DESCRIPTION	PARTS NO.	QTY.
1	3 Phase Motor 51K40GNS	A2EU-5IK40GNS	1
2	Gear Box 5GN9K	A2RG-5GN9K-1	1
3	Double Head Round Keys	RGM-4415	1
4	Spacing Rod	WB1-ELF-016B	4
5	Spring Washer	2FWO-M6	4
6	Socket Head Cap Screws	XNJW-M665	4
7	Socket Assembly Screw	XN5Z-M45	1
8	Pulley 19T	CV1-ELF-017	1

WRAP STATION DRIVING PULLING ASSEMBLY

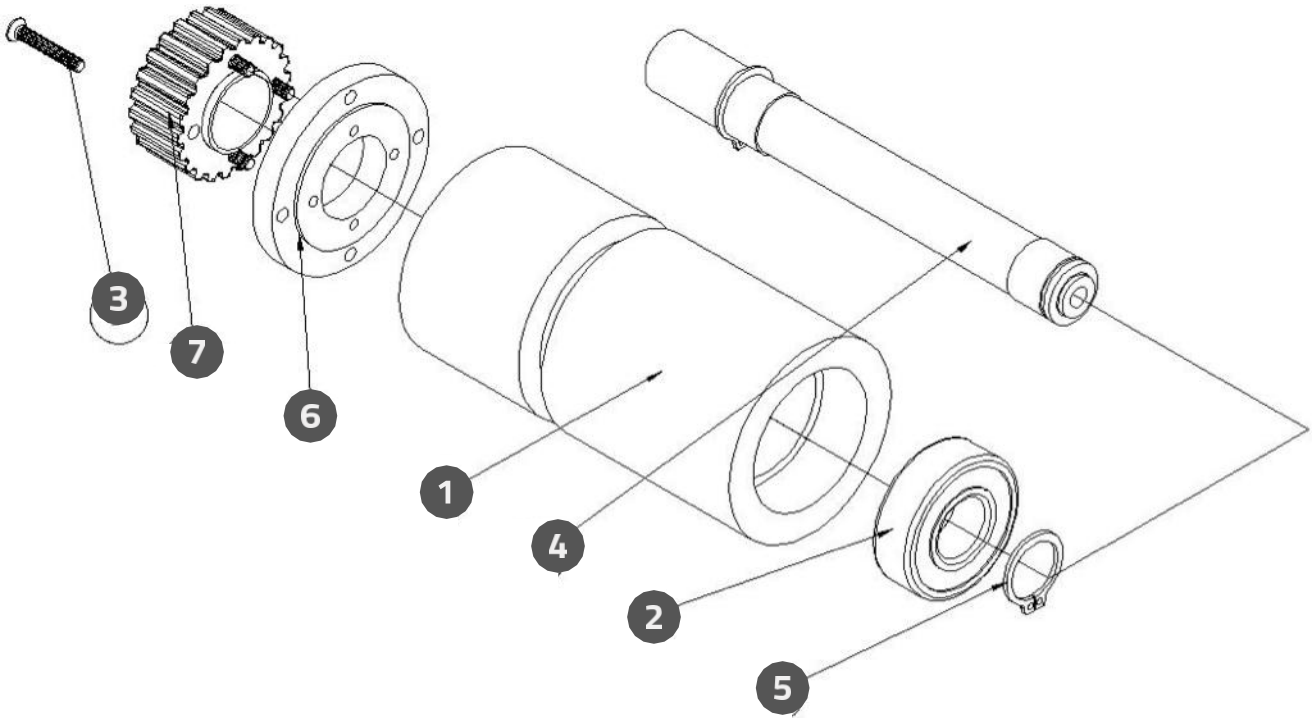

WRAP STATION DRIVING PULLING ASSEMBLY PART LIST

NO.	DESCRIPTION	PARTS NO.	QTY.
1	Driving Pulley	WB1-ELF-003B	1
2	Bearing 6202ZZ	5TGH-6202ZZ	2
3	Bolt	XNAW-M320	4
4	Driving Pulley Shaft	WB1-ELF-004C	1
5	S-Ring S15	DCSV-S15	2
6	Driving Pulley Cover	CV1-ELF-003B	1
7	Driving Pulley Gear	CV1-ELF-004	1

WRAP STATION DRIVEN PULLEY ASSEMBLY

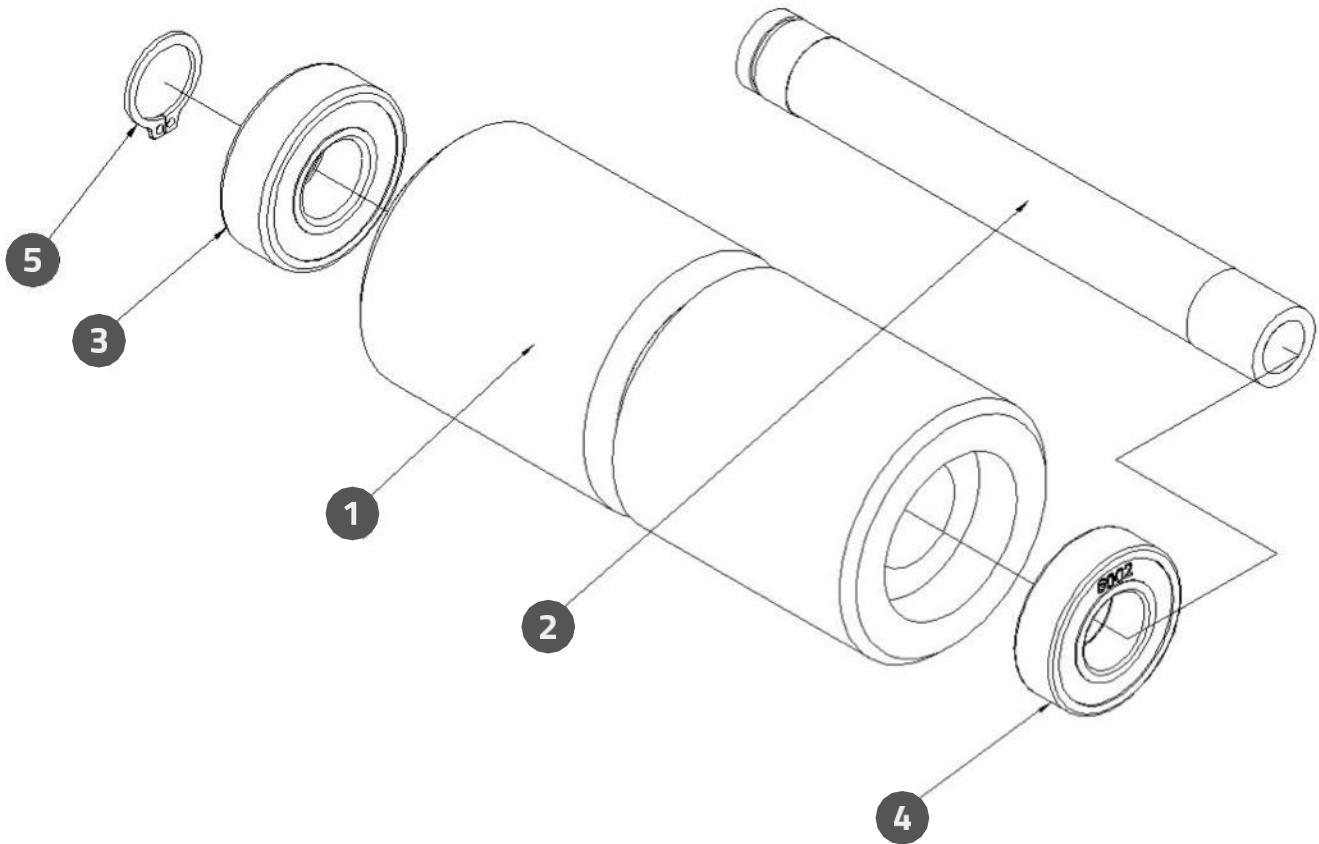

WRAP STATION DRIVEN PULLEY ASSEMBLY PART LIST

NO.	DESCRIPTION	PARTS NO.	QTY.
1	Driven Pulley	WB1-ELF-005B	1
2	Driven Pulley Shaft	WB1-ELF-006B	1
3	Bearing 6002ZZ	5TGH-6002ZZ	1
4	Bearing 6002ZZ	5TGH-6002ZZ	1
5	S-Ring S15	DCSV-S15	1

SPACE ROLLER ASSEMBLY 1

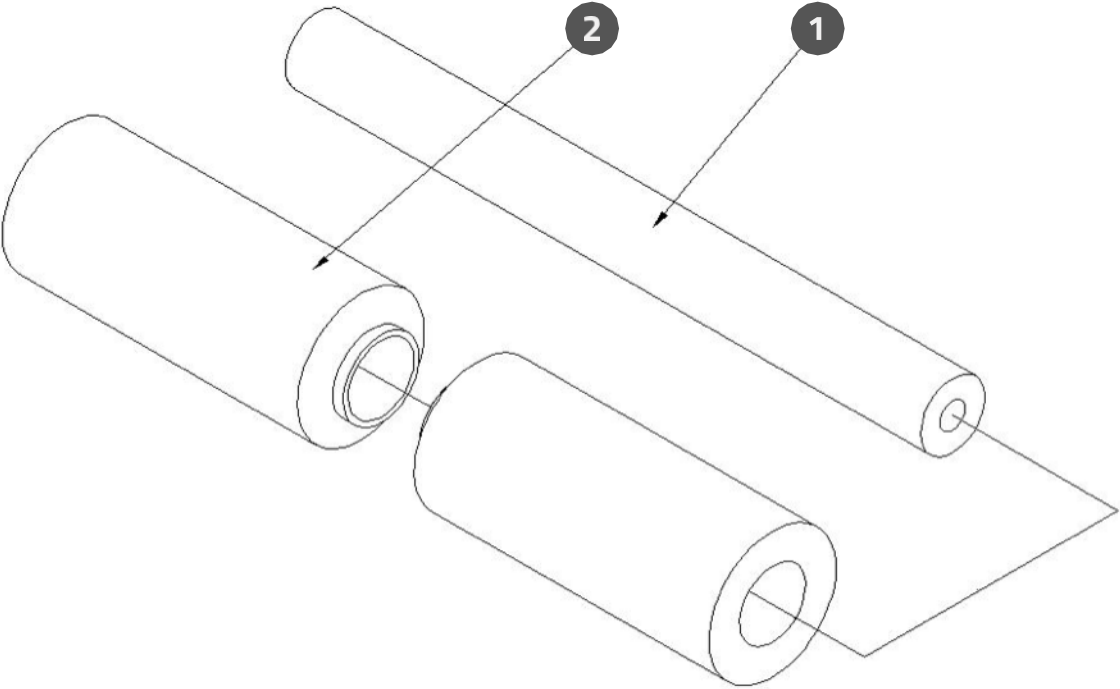

SPACE ROLLER ASSEMBLY 1 PART LIST



NO.	DESCRIPTION	PARTS NO.	QTY.
1	Spacing Rods	WB1-ELF-008	1
2	Spacing Roller	WB1-ELF-007	2

SPACE ROLLER ASSEMBLY 2

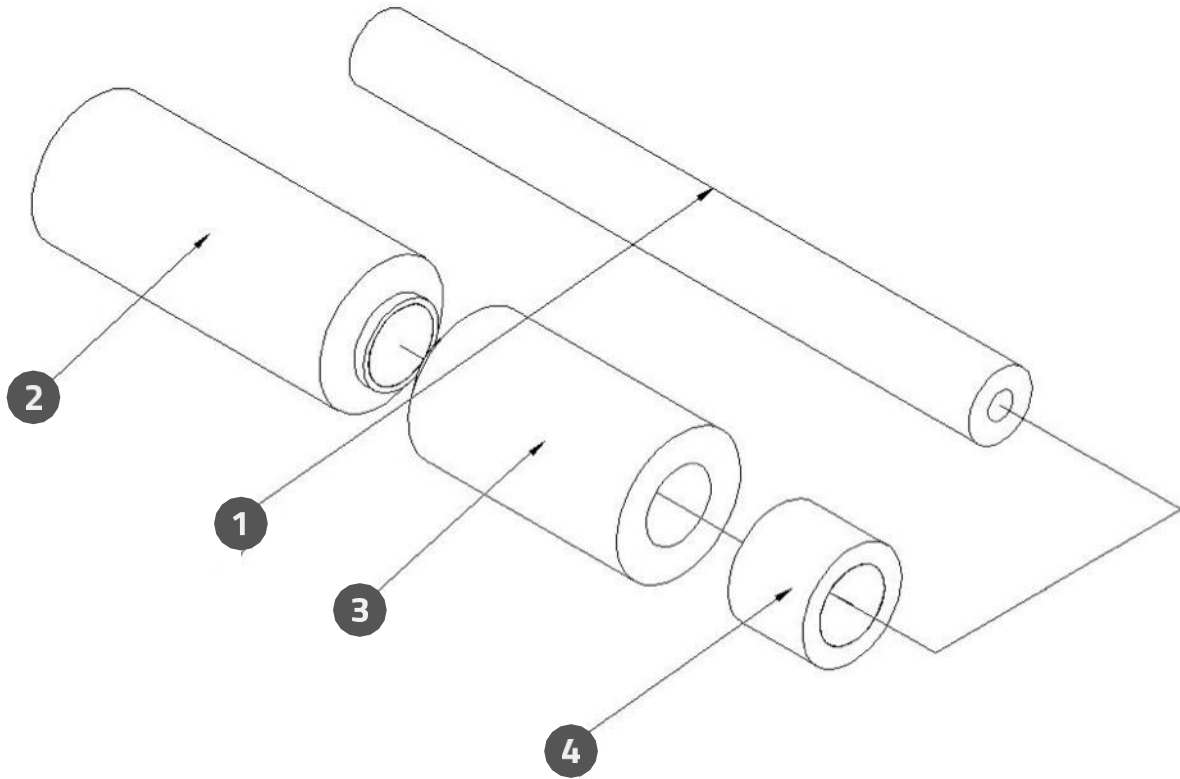

SPACE ROLLER ASSEMBLY 2 PART LIST

NO.	DESCRIPTION	PARTS NO.	QTY.
1	Spacing Rods	WB1-ELF-008	1
2	Spacing Roller	WB1-ELF-007	1
3	Spacing Roller(Short)	WB1-ELF-009	1
4	Friction Roller	WB1-ELF-010	1

WRAP STATION UP/DOWN ADJUSTMENT ASSEMBLY

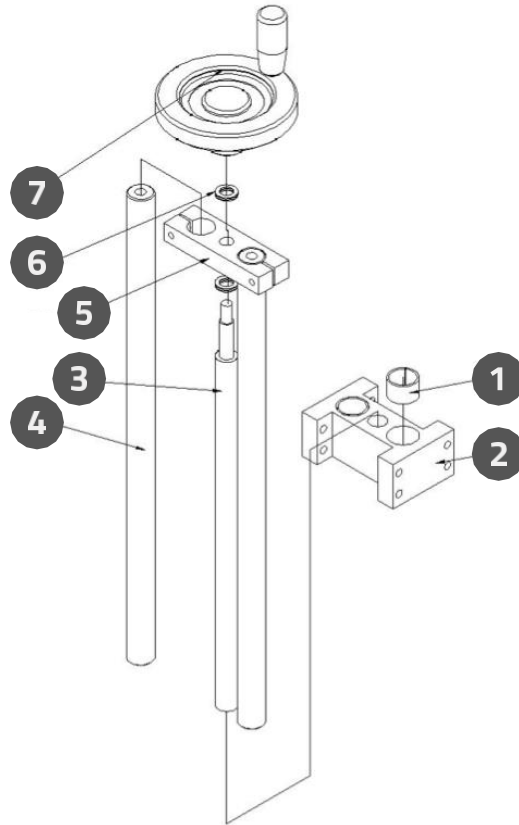

WRAP STATION UP/DOWN ADJUSTMENT ASSEMBLY PART LIST

NO.	DESCRIPTION	PARTS NO.	QTY.
1	Self Run Bearing	5TDU-LBF2015	4
2	Adjustment Base	AA1-ELF-001B	1
3	Screw Rod M16300	AA1-ELF-007	1
4	Sliding Shaft D20400	AA1-ELF-004	2
5	Hand Wheel Base	AA1-ELF-014	1
6	Nylon Washer	2FN2-101610	6
7	Hand Wheel	QRGX-KRA100CB65	1



PRESSUREPLATE

PRESSURE PLATE ASSEMBLY

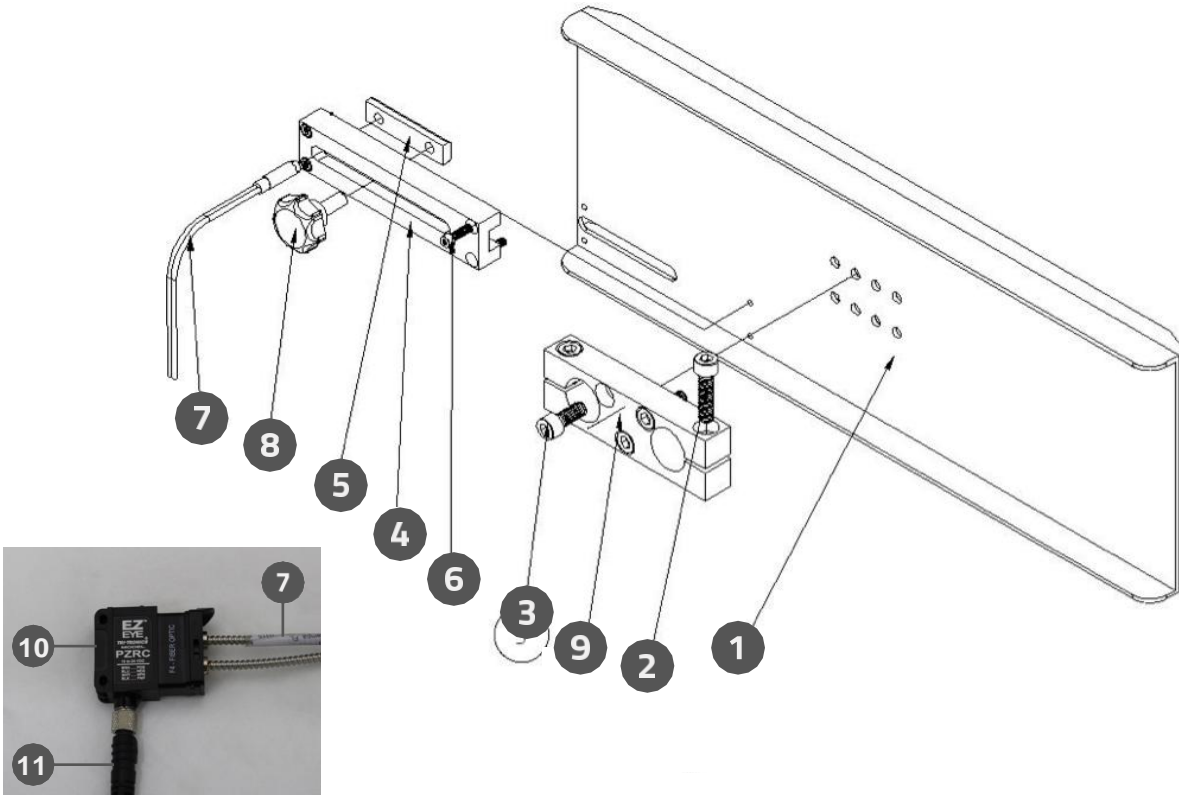

PRESSURE PLATE ASSEMBLY PART LIST



NO.	DESCRIPTION	PARTS NO.	QTY.
1	Pressure Plate	WB1-ELF-017B	1
2	Socket Head Cap Screws	XNJW-M625	2
3	Socket Head Cap Screws	XNJW-M616	3
4	Adjustment Seat Of Sensor	WB1-ELF-015B	1
5	Fixed Seat Of Sensor	WB1-PL160-016	1
6	Socket Head Cap Screws	XMNW-M312	6
7	Product Sensor	2YE2-PZRCF4GEC-6	1
8	Knob	51WR-606025M615	1
9	Fixed Seat Of Pressure Plate	AA1-ELF-013	1
10	Sensor Amplifier	TT-PZRC-F4	1
11	M8 Connecting Cable	GEC-6	1

PRESSURE PLATE ADJUSTMENT ASSEMBLY

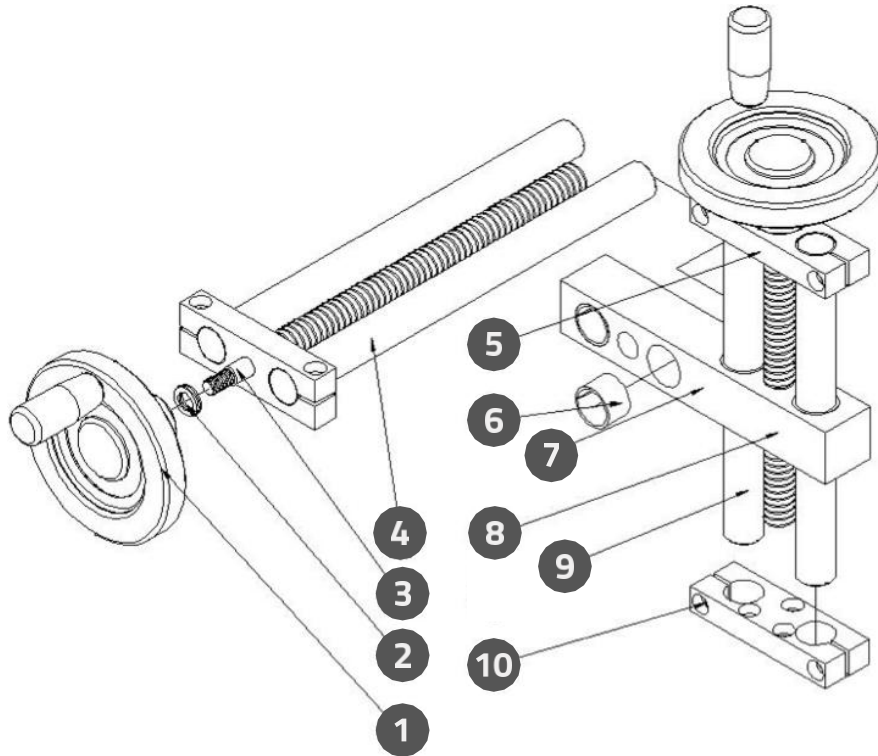

PRESSURE PLATE ADJUSTMENT ASSEMBLY PART LIST

NO.	DESCRIPTION	PARTS NO.	QTY.
1	Hand Wheel	QRGX-KRA100CB65	2
2	Nylon Washer	2FN2-101610	12
3	Screw RodM16210	AA1-ELF-015	1
4	Sliding Shaft	512C-20D250L	2
5	Mounting Base of Hand Wheel	AA1-ELF-014	2
6	Self Run Bearing	5TDU-LBF2015	8
7	Pressure Plate Sliding Block	AA1-ELF-011B	1
8	Screw RodM16160	AA1-ELF-008	1
9	Sliding Shaft D20200	AA1-ELF-006	2
10	Fixture of Pressure Plate	AA1-ELF-013	1



CONVEYOR

CONVEYOR ASSEMBLY

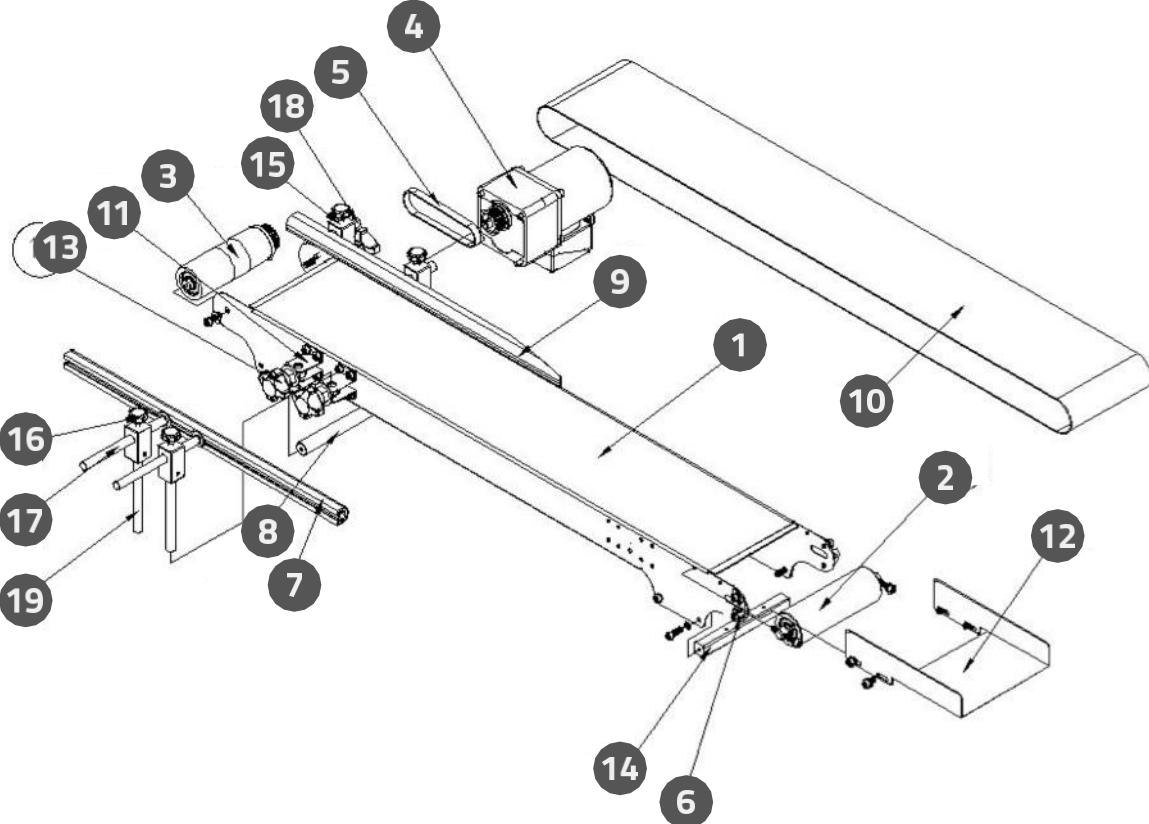

CONVEYOR ASSEMBLY PART LIST

NO.	DESCRIPTION	PARTS NO.	QTY.
1	Conveyor Plate	CV1-ELF-001C	1
2	Conveyor Driven Pulley Assembly	See page63	1
3	Conveyor Driving Pulley Assembly	See page62	1
4	Conveyor Motor Assembly	See page61	1
5	Timing Belt 120XL-050	T2Q2-120XL050	1
6	Tension Adjustment Block	CV1-ELF-008	2
7	Guide Rail -1	GR1-ELF-001B	1
8	Spacing Pillar	CV1-ELF-010	4
9	Guide Rail -2	GR1-ELF-002	1
10	Conveyor Belt 150W*2040L	T2EW-150W2040LA	1
11	Guide Rail Fixing Base	CV1-ELF-011	8
12	Bridging Plate	CV1-ELF-012	1
13	Locking Screw Q339	51WR-Q339	4
14	Heater Box Fixed Rod	CV1-ELF-020	2
15	Guide Rail Front & Back Positioned Rod	GR1-PL501-009	4
16	Star Knob	51WR-606025M615	4
17	Guide Rail Front & Back Adjusting Rod	51CX-K-PIN-150	2
18	Guide Rail Front & Back Adjusting Rod	51CX-K-PIN-30	2
19	Guide Rail Up & Down Adjusting Rod	51CX-UD-D12140	4

CONVEYOR MOTOR ASSEMBLY

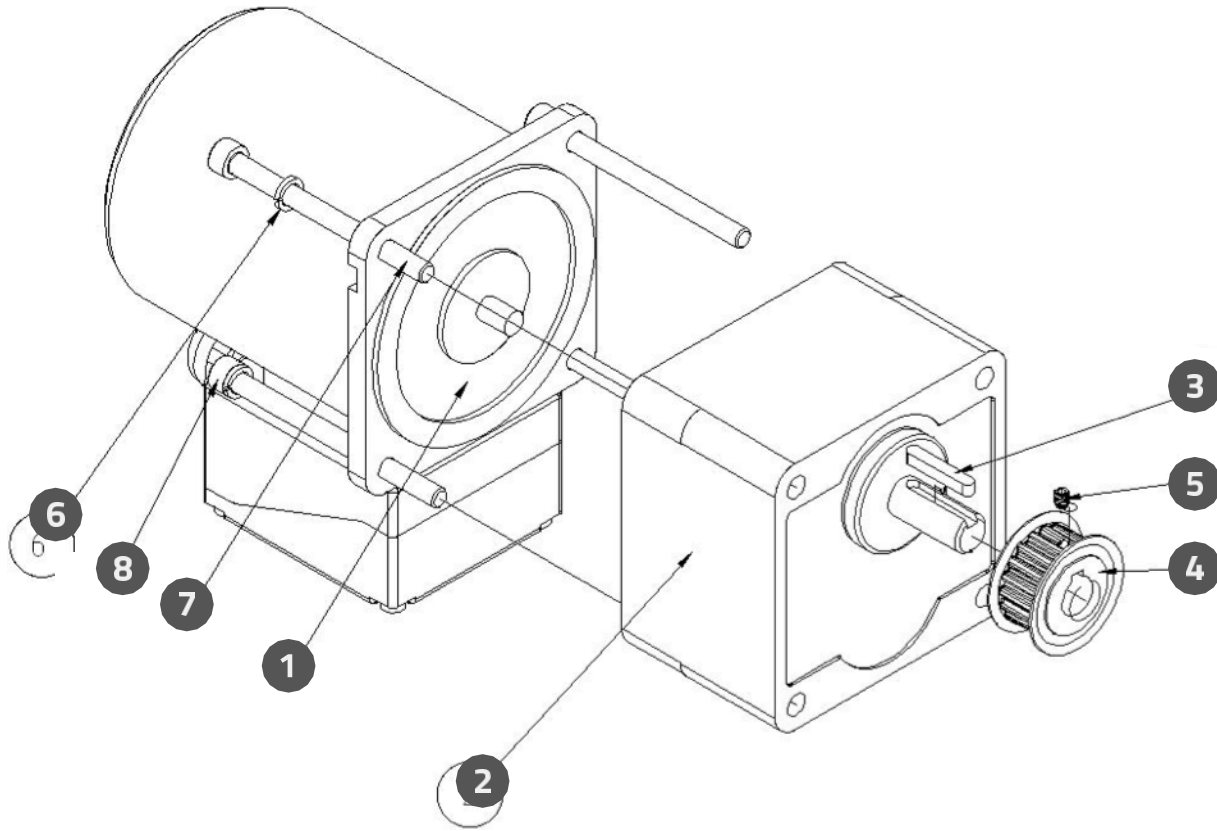

CONVEYOR MOTOR ASSEMBLY PART LIST

NO.	DESCRIPTION	PARTS NO.	QTY.
1	3 Phase Stepper Motor	A2EU-51K40GNST	1
2	Gear Reducer 5GN15K	A2RG-5GN15K-1	1
3	Double Head Round Keys	RGM-4425	1
4	Pulley	CV1-ELF-017	1
5	Socket SetScrew	XN5Z-M45	1
6	Spring Washer	2FWO-M6	4
7	Socket Head Cap Screws	XNJW-M675	2
8	Socket Head Cap Screws	XNJW-M685	2

CONVEYOR DRIVING PULLEY ASSEMBLY

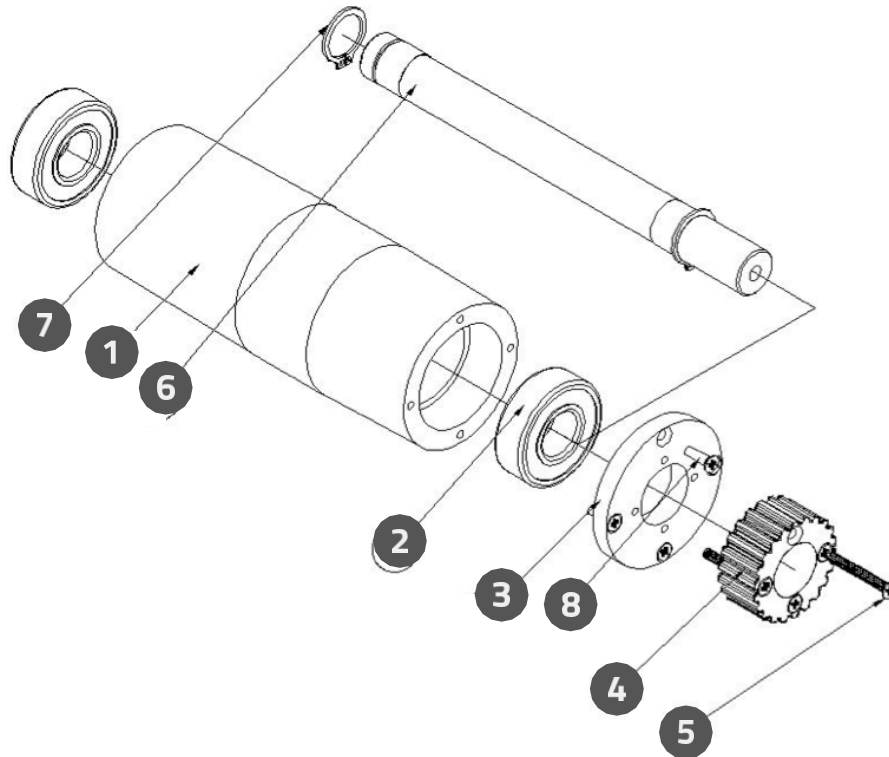

CONVEYOR DRIVING PULLEY ASSEMBLY PARTLIST

NO.	DESCRIPTION	PARTS NO.	QTY.
1	Conveyor Driving Pulley	CV1-ELF-002B	1
2	Bearing 6202ZZ	5TGH-6202ZZ	2
3	ConveyorDrivingPulleyCover	CV1-ELF-003B	1
4	Gear	CV1-ELF-004	1
5	Bolt	XNAW-M320	4
6	ConveyorDrivingPulleyShaft	CV1-ELF-005B	1
7	S-Ring S15	DCSV-S15	2
8	Bolt	XNAW-M315	4

CONVEYOR DRIVEN PULLEY ASSEMBLY

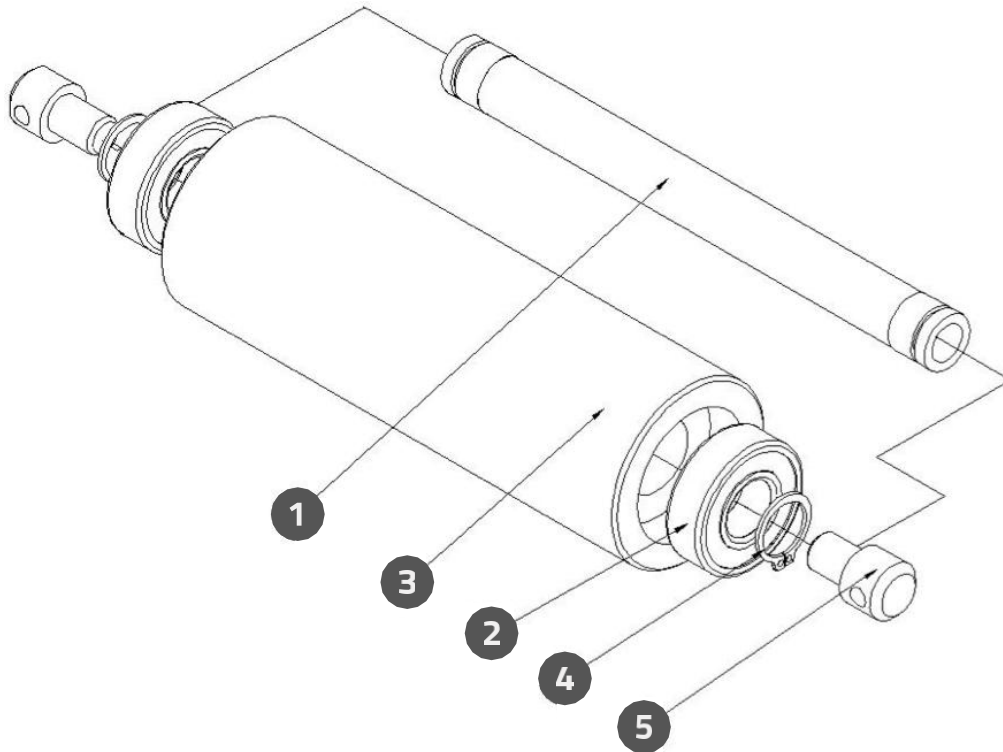

CONVEYOR DRIVEN PULLEY ASSEMBLY PARTLIST

NO.	DESCRIPTION	PARTS NO.	QTY.
1	Conveyor Driven Pulley	CV1-ELF-007B	1
2	Bearing 6202ZZ	5TGH-6202ZZ	2
3	Conveyor Driven Pulley Shaft	CV1-ELF-006B	1
4	S-Ring	DCSV-S15	2
5	Pulley Adjustment Block	CV1-ELF-009	2



FOOT STAND

FOOT STAND ASSEMBLY

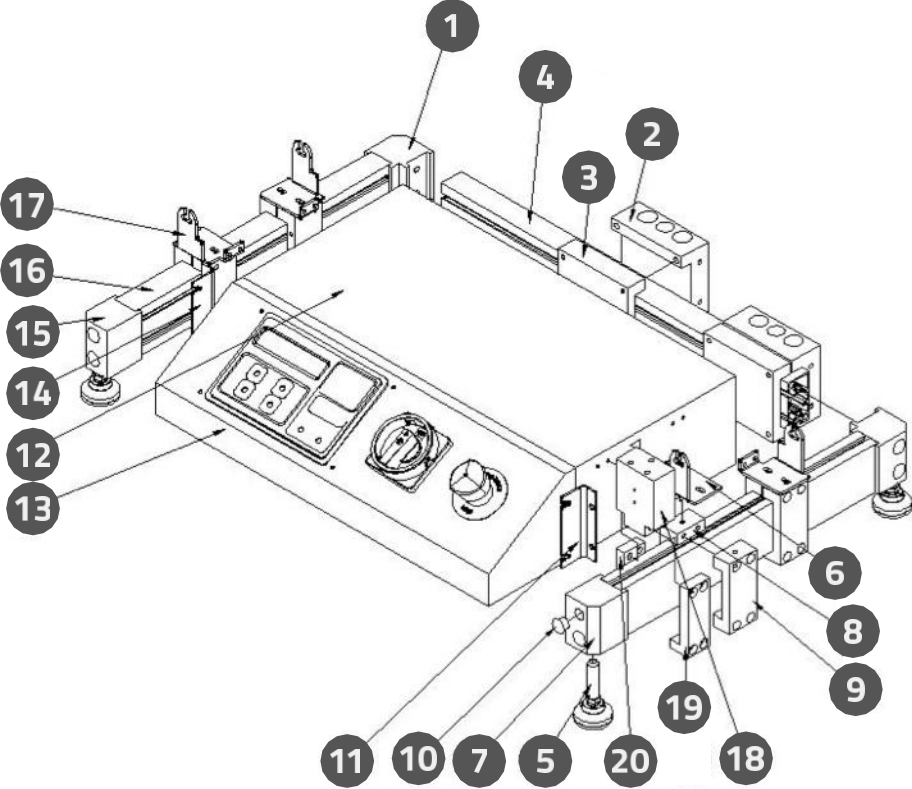

FOOT STAND ASSEMBLY PART LIST

NO.	DESCRIPTION	PARTS NO.	QTY.
1	Stand Connector	FT1-ELF-014C	2
2	Supporter Connecting Base	FT1-ELF-025C	2
3	SupporterConnecting Base (Inner)	FT1-ELF-026C	2
4	Back Stand Connector	FT1-ELF-034C	1
5	Pad	51WR-NS401285	4
6	Conveyor Supporter-Right	FT1-ELF-023E	2
7	Stand Connector-Front Right	FT1-ELF-033	1
8	Conveyor Fixed Supporter(Inner)	FT1-ELF-018D	4
9	Conveyor Fixed Supporter (Outer)	FT1-ELF-017C	4
10	Plug	QVDG-HP13	12
11	Control Box Panel Fixed Plate (Right)	FT1-ELF-021	1
12	Control Box Cover	CS1-ELF-006	1
13	Panel	CS1-ELF-002B	1
14	Control Box Panel Fixed Plate(Left)	FT1-ELF-022	1
15	Stand Connector-Front Left	FT1-ELF-032	1
16	Aluminum Extrusion	FT1-ELF-035	2
17	Conveyor Supporter-Left	FT1-ELF-024E	2
18	Adjustment Fixed Base	FT1-ELF-028C	1
19	AdjustmentFixedBase(Outer)	FT1-ELF-029B	1
20	AdjustmentFixedBase(Inner)	FT1-ELF-030B	1



www.PackLeaderUSA.com
3951 E.137th Terrace
Grandview, MO 64030

sales@packleaderusa.com
Phone: 1.816.581.4330
Parts & Service: 1.816.788.6689